

SPECIFICATION FOR APPROVAL

承 认 书

CUSTOMER

NUMBER

客户名称:

编 号: 标准系列

DESCRIPTION

QUANTITY

品 名: 贴片电感

数 量: 10PCS

PART NO.

DATE

型 号: 一体成型系列(铁粉)

日 期: 2019/11/19

CUSTOMER PART NO.

NOTE

客户料号:

注 解:

APPROVAL SIGNATURE 客户承认盖章

APPROVED BY 核 准	Q. C. DEPT. 品 管	CHECKED BY 核 查	DRAWN BY 制 作

产品外观 Product appearance:



原理图 Schematic Diagram:

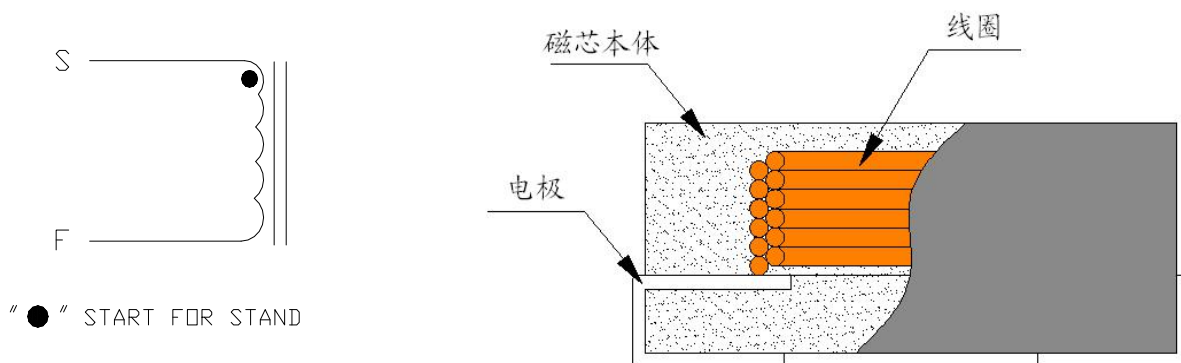

产品识别 PRODUCT IDENTIFICATION:

S H C
↓
S: SMD
H: High
C: Choke

1005
↓
外形尺寸:
10.3*10.5*5.0mm

Y — 1R0
↓
H: 合金粉
T: 羰基铁粉
TF: 羰基不锈钢粉
Y: 压边, 无Y为平面
无字母: 还原铁粉

电感量:
1R0: 1.0UH
220: 22UH
221: 220UH

M
↓
M: ±20%
N: ±30%

产品系列 PRODUCT SERIES

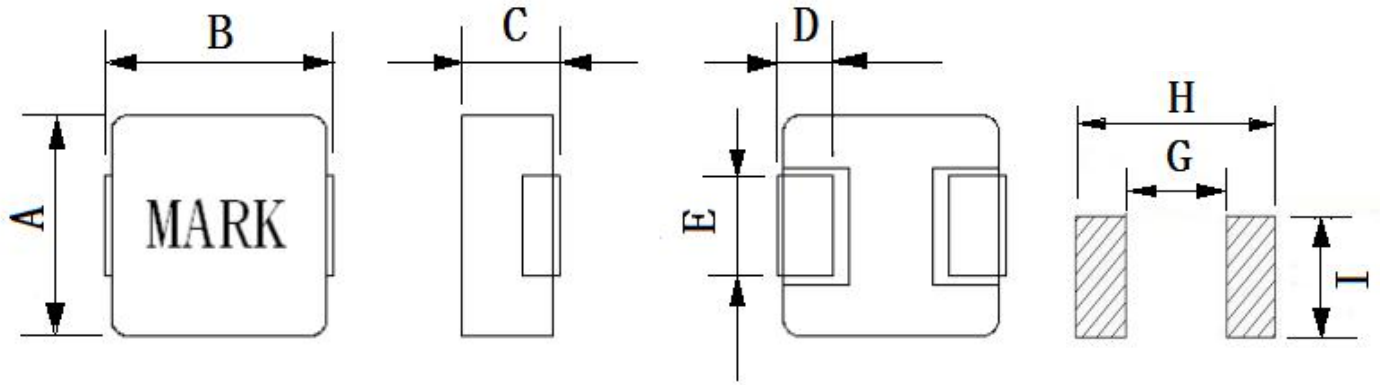

Part No.	A	B	C(Max.)	D	E	G(Ref.)	H(Ref.)	I(Ref.)
SHC0503	5.18 ± 0.3	5.49 ± 0.4	3.00	1.2 ± 0.3	2.0 ± 0.3	1.80	5.80	2.50
SHC06024	6.6 ± 0.2	7.4 Max.	2.40	1.6 ± 0.3	3.0 ± 0.2	2.50	7.50	3.50
SHC0603	6.6 ± 0.2	7.4 Max.	3.00	1.6 ± 0.3	3.0 ± 0.2	2.50	7.50	3.50
SHC0604	6.6 ± 0.2	7.6 Max.	4.00	1.6 ± 0.3	3.0 ± 0.2	2.80	7.80	3.50
SHC0605	6.6 ± 0.2	7.6 Max.	5.00	1.6 ± 0.3	3.0 ± 0.2	2.80	7.80	3.50
SHC0805	8.0 ± 0.3	9.2 Max.	5.00	1.8 ± 0.3	3.0 ± 0.2	4.30	9.30	3.70
SHC1004	10.3 ± 0.3	10.5 ± 1.0	4.00	2.0 ± 0.5	3.0 ± 0.3	4.85	11.85	3.80
SHC10045	10.3 ± 0.3	10.5 ± 1.0	4.50	2.0 ± 0.5	3.0 ± 0.3	4.85	11.85	3.80
SHC1005	10.3 ± 0.3	10.5 ± 1.0	5.00	2.0 ± 0.5	3.0 ± 0.3	4.85	11.85	3.80
SHC1204	12.8 ± 0.5	13.2 ± 1.0	4.00	2.5 ± 0.5	3.8 ± 0.3	5.20	14.40	5.00
SHC1205	12.8 ± 0.5	13.2 ± 1.0	5.00	2.5 ± 0.5	3.8 ± 0.3	5.20	14.40	5.00
SHC1206	12.8 ± 0.5	13.2 ± 1.0	6.00	2.5 ± 0.5	3.8 ± 0.3	5.20	14.40	5.00
SHC12065	12.8 ± 0.5	13.2 ± 1.0	6.50	2.5 ± 0.5	3.8 ± 0.3	5.20	14.40	5.00
SHC1707	17.15 Max.	17.5 ± 1.0	7.00	2.0 ± 0.5	11.94 ± 0.3	9.20	18.40	13.00
SHC2213	22.0 ± 0.5	22.5 ± 0.5	13.00	5.0 ± 0.5	18.6 ± 0.3	11.56	22.36	18.80

特性参数 Characteristic Data:

产品料号 Part NO.	L0 (μH) @100kHz /1.0V	直流电阻 DCR (mΩ)		额定电流 I _{rms} (A)	饱和电流 I _{sat} (A)
		Typ.	Max.	Typ.	Typ.
SHC0503-100M	10.00	110.00	132.00	2.50	4.50
SHC0503-150M	15.00	143.00	163.00	2.50	4.00
SHC0503-220M	22.00	270.00	324.00	2.00	3.50
SHC0503-330M	33.00	330.00	372.00	1.20	2.50

产品料号 Part NO.	L0 (μH) @100kHz /1.0V	直流电阻 DCR (mΩ)		额定电流 I rms (A)	饱和电流 I sat (A)
		Typ.	Max.	Typ.	Typ.
SHC06024Y-R10M	0.10	1.80	3.50	30.00	50.00
SHC06024Y-R22M	0.22	1.70	3.20	12.00	21.00
SHC06024Y-R47M	0.47	4.00	6.50	10.00	18.00
SHC06024Y-R68M	0.68	6.00	9.40	9.00	16.00
SHC06024Y-R82M	0.82	8.70	11.80	8.50	15.00
SHC06024Y-1R0M	1.00	9.00	12.00	8.00	13.00
SHC06024Y-1R5M	1.50	14.00	17.00	7.00	12.00
SHC06024Y-2R2M	2.20	22.00	34.00	6.00	10.00
SHC06024Y-3R3M	3.30	29.00	35.00	5.00	9.00
SHC06024Y-4R7M	4.70	41.00	50.00	5.00	8.00
SHC06024Y-6R8M	6.80	52.00	72.00	3.00	6.00
SHC06024Y-8R2M	8.20	82.00	72.00	2.80	5.00
SHC06024Y-100M	10.00	82.00	106.00	2.00	4.00
SHC06024Y-150M	15.00	112.00	135.00	1.50	3.00

产品料号 Part NO.	L0 (μH) @100kHz /1.0V	直流电阻 DCR (mΩ)		额定电流 I rms (A)	饱和电流 I sat (A)
		Typ.	Max.	Typ.	Typ.
SHC0603-6R8M	6.80	45.00	54.00	4.00	7.00
SHC0603-8R2M	8.20	60.00	72.00	3.50	6.00
SHC0603-100M	10.00	61.00	76.00	3.00	5.00
SHC0603-150M	15.00	100.00	130.00	2.50	4.50
SHC0603-220M	22.00	127.00	152.00	2.00	3.50
SHC0603-330M	33.00	170.00	222.00	1.50	3.00
SHC0603-470M	47.00	210.00	290.00	1.20	2.50
SHC0603-101M	100.00	715.00	858.00	1.00	1.70

产品料号 Part NO.	L0 (μH) @100kHz /1.0V	直流电阻 DCR (mΩ)		额定电流 I rms (A)	饱和电流 I sat (A)
		Typ.	Max.	Typ.	Typ.
SHC0604-R47M	0.47	3.00	3.60	15.00	26.00
SHC0604-R68M	0.68	4.80	5.80	10.00	18.00
SHC0604-1R0M	1.00	5.50	6.60	9.00	17.00
SHC0604-1R5M	1.50	7.00	10.80	8.00	13.00
SHC0604-2R2M	2.20	10.00	13.00	7.00	12.00
SHC0604-3R3M	3.30	13.50	18.00	6.50	11.00

SHC0604-4R7M	4.70	20.00	24.00	6.00	9.00
SHC0604-6R8M	6.80	41.00	49.00	5.00	8.00
SHC0604-8R2M	8.20	58.00	70.00	4.00	7.00
SHC0604-100M	10.00	58.00	70.00	3.50	6.50
SHC0604-150M	15.00	64.00	77.00	3.00	5.50
SHC0604-220M	22.00	98.00	117.00	2.50	4.00
SHC0604-330M	33.00	163.00	196.00	2.00	3.50

产品料号 Part NO.	L0 (μH) @100kHz /1.0V	直流电阻 DCR (mΩ)		额定电流 I _{rms} (A)	饱和电流 I _{sat} (A)
		Typ.	Max.	Typ.	Typ.
SHC0605-R68M	0.68	4.50	5.40	11.00	20.00
SHC0605-R82M	0.82	6.00	7.20	10.00	19.00
SHC0605-1R0M	1.00	6.00	7.20	9.00	18.00
SHC0605-1R5M	1.50	7.00	8.50	8.50	15.00
SHC0605-2R2M	2.20	10.40	12.50	8.00	14.00
SHC0605-3R3M	3.30	13.00	16.00	7.00	11.00
SHC0605-4R7M	4.70	17.00	20.00	6.00	10.00
SHC0605-6R8M	6.80	22.00	26.40	5.00	9.00
SHC0605-8R2M	8.20	33.00	45.00	4.50	8.50
SHC0605-100M	10.00	37.00	46.00	4.00	8.00
SHC0605-150M	15.00	54.00	65.00	3.50	6.00
SHC0605-220M	22.00	80.00	105.00	3.00	5.00
SHC0605-330M	33.00	120.00	144.00	2.50	4.50
SHC0605-470M	47.00	170.00	200.00	1.50	2.50
SHC0605-560M	56.00	202.00	242.00	1.40	2.40
SHC0605-101M	100.00	265.00	320.00	1.00	2.00

产品料号 Part NO.	L0 (μH) @100kHz /1.0V	直流电阻 DCR (mΩ)		额定电流 I _{rms} (A)	饱和电流 I _{sat} (A)
		Typ.	Max.	Typ.	Typ.
SHC0805-R82M	0.82	4.00	4.80	16.00	24.00
SHC0805-1R0M	1.00	4.70	5.60	14.00	21.00
SHC0805-2R2M	2.20	7.50	9.00	11.00	18.00
SHC0805-3R3M	3.30	11.00	13.00	10.00	15.00
SHC0805-4R7M	4.70	16.00	20.00	8.00	14.00
SHC0805-6R8M	6.80	20.00	24.00	6.00	11.00
SHC0805-100M	10.00	30.00	36.00	5.00	10.00

SHC0805-150M	15.00	46.00	55.00	4.00	7.50
SHC0805-220M	22.00	78.00	94.00	3.50	7.00
SHC0805-330M	33.00	125.00	150.00	3.00	6.00
SHC0805-470M	47.00	160.00	192.00	2.50	4.00
SHC0805-560M	56.00	170.00	205.00	2.00	3.50
SHC0805-680M	68.00	188.00	233.00	1.50	3.00
SHC0805-101M	100.00	272.00	326.00	1.20	2.00

产品料号 Part NO.	L0 (μH) @100kHz /1.0V	直流电阻 DCR (mΩ)		额定电流 I _{rms} (A)	饱和电流 I _{sat} (A)
		Typ.	Max.	Typ.	Typ.
SHC1004Y-R22M	0.22	0.80	1.00	30.00	54.00
SHC1004Y-R36M	0.36	1.10	1.40	25.00	45.00
SHC1004Y-R47M	0.47	1.20	1.50	20.00	35.00
SHC1004Y-R56M	0.56	1.60	1.90	18.00	34.00
SHC1004Y-R68M	0.68	1.60	1.90	17.00	32.00
SHC1004Y-R82M	0.82	1.80	2.40	16.00	28.00
SHC1004Y-1R0M	1.00	2.10	2.50	15.00	23.00
SHC1004Y-1R5M	1.50	4.40	5.30	14.00	22.00
SHC1004Y-2R2M	2.20	6.40	7.00	11.00	18.00
SHC1004Y-3R3M	3.30	9.00	11.50	10.00	17.00
SHC1004Y-4R7M	4.70	12.00	15.00	8.00	13.00
SHC1004Y-5R6M	5.60	16.00	19.20	7.00	12.00
SHC1004Y-6R8M	6.80	17.50	22.00	6.00	11.00
SHC1004Y-8R2M	8.20	27.00	32.00	5.50	10.00
SHC1004Y-100M	10.00	31.00	40.00	5.00	9.00

产品料号 Part NO.	L0 (μH) @100kHz /1.0V	直流电阻 DCR (mΩ)		额定电流 I _{rms} (A)	饱和电流 I _{sat} (A)
		Typ.	Max.	Typ.	Typ.
SHC10045Y-150M	15.00	37.00	60.00	4.00	8.00
SHC10045Y-220M	22.00	54.00	72.00	4.00	6.00
SHC10045Y-330M	33.00	82.00	105.00	3.50	5.00
SHC10045Y-470M	47.00	128.00	158.00	2.50	4.50
SHC10045Y-101M	100.00	237.00	290.00	2.00	3.50

产品料号 Part NO.	L0 (μH) @100kHz /1.0V	直流电阻 DCR (mΩ)		额定电流 I _{rms} (A)	饱和电流 I _{sat} (A)
		Typ.	Max.	Typ.	Typ.

SHC1005Y-R82M	0.82	1.80	2.20	18.00	34.00
SHC1005Y-1R0M	1.00	2.10	2.50	16.00	28.00
SHC1005Y-1R2M	1.20	2.30	2.80	15.00	26.00
SHC1005Y-1R5M	1.50	2.60	3.10	13.00	21.00
SHC1005Y-2R2M	2.20	5.20	7.00	11.00	20.00
SHC1005Y-3R3M	3.30	6.00	7.80	10.00	16.00
SHC1005Y-4R7M	4.70	10.80	12.00	9.00	15.00
SHC1005Y-5R6M	5.60	13.50	16.00	8.00	14.00
SHC1005Y-6R8M	6.80	13.50	16.00	7.50	13.00
SHC1005Y-8R2M	8.20	22.00	25.00	7.00	12.50
SHC1005Y-100M	10.00	23.00	28.00	6.00	12.00
SHC1005Y-150M	15.00	33.00	42.00	5.00	10.00
SHC1005Y-220M	22.00	58.00	70.00	4.50	8.00
SHC1005Y-330M	33.00	85.00	105.00	4.00	6.00
SHC1005Y-470M	47.00	127.00	152.00	3.50	5.50
SHC1005Y-680M	68.00	198.00	258.00	3.00	5.00
SHC1005Y-820M	82.00	220.00	264.00	2.50	4.50
SHC1005Y-101M	100.00	230.00	279.00	2.00	4.00
SHC1005Y-151M	150.00	412.00	495.00	1.50	3.00

产品料号 Part NO.	L0 (μH) @100kHz /1.0V	直流电阻 DCR (mΩ)		额定电流 I _{rms} (A)	饱和电流 I _{sat} (A)
		Typ.	Max.	Typ.	Typ.
SHC1204Y-R22M	0.22	0.70	0.90	35.00	55.00
SHC1204Y-R33M	0.33	0.80	1.50	30.00	50.00
SHC1204Y-R47M	0.47	1.30	1.60	25.00	45.00
SHC1204Y-R56M	0.56	1.50	1.80	22.00	42.00
SHC1204Y-R68M	0.68	1.70	2.00	20.00	40.00
SHC1204Y-1R0M	1.00	2.90	3.50	18.00	38.00
SHC1204Y-1R5M	1.50	4.40	5.30	15.00	30.00
SHC1204Y-2R2M	2.20	5.00	6.50	12.00	20.00
SHC1204Y-3R3M	3.30	6.70	8.00	11.00	18.00
SHC1204Y-4R7M	4.70	14.50	17.50	10.00	16.00
SHC1204Y-5R6M	5.60	14.50	17.50	8.00	15.00
SHC1204Y-6R8M	6.80	19.00	30.00	6.00	11.00
SHC1204Y-100M	10.00	27.00	33.00	5.00	8.00

SHC1204Y-220M	22.00	49.00	58.00	4.00	7.00
---------------	-------	-------	-------	------	------

产品料号 Part NO.	L0 (μH) @100kHz /1.0V	直流电阻 DCR (mΩ)		额定电流 I _{rms} (A)	饱和电流 I _{sat} (A)
		Typ.	Max.	Typ.	Typ.
SHC1205Y-R36M	0.36	1.00	1.20	40.00	60.00
SHC1205Y-R47M	0.47	1.00	1.20	25.00	45.00
SHC1205Y-R56M	0.56	1.00	1.20	24.00	40.00
SHC1205Y-R68M	0.68	1.20	1.60	23.00	38.00
SHC1205Y-R82M	0.82	1.70	2.20	22.00	36.00
SHC1205Y-1R0M	1.00	2.10	2.50	20.00	35.00
SHC1205Y-1R2M	1.20	2.10	2.60	16.00	32.00
SHC1205Y-1R5M	1.50	2.60	3.10	15.00	30.00
SHC1205Y-2R2M	2.20	5.00	6.00	14.00	26.00
SHC1205Y-3R3M	3.30	6.30	7.60	13.00	24.00
SHC1205Y-4R7M	4.70	7.50	9.00	12.00	18.00
SHC1205Y-5R6M	5.60	7.50	10.50	9.00	15.00
SHC1205Y-6R8M	6.80	12.00	14.40	8.00	13.00
SHC1205Y-8R2M	8.20	18.00	22.00	7.50	12.00
SHC1205Y-100M	10.00	19.50	24.00	7.00	11.00
SHC1205Y-150M	15.00	26.00	31.20	5.00	9.00
SHC1205Y-220M	22.00	29.00	35.00	4.00	7.00
SHC1205Y-330M	33.00	52.00	63.00	3.00	6.00
SHC1205Y-470M	47.00	85.00	102.00	2.50	5.00

产品料号 Part NO.	L0 (μH) @100kHz /1.0V	直流电阻 DCR (mΩ)		额定电流 I _{rms} (A)	饱和电流 I _{sat} (A)
		Typ.	Max.	Typ.	Typ.
SHC1206Y-R68M	0.68	1.10	1.80	30.00	45.00
SHC1206Y-R82M	0.82	1.50	2.40	25.00	42.00
SHC1206Y-1R0M	1.00	2.20	2.60	24.00	40.00
SHC1206Y-1R5M	1.50	2.10	4.10	18.00	30.00
SHC1206Y-2R2M	2.20	5.00	6.00	16.00	28.00
SHC1206Y-3R3M	3.30	5.40	6.50	15.00	26.00
SHC1206Y-4R7M	4.70	7.50	9.00	14.00	24.00
SHC1206Y-5R6M	5.60	7.70	10.00	12.00	18.00
SHC1206Y-6R8M	6.80	8.40	10.00	10.00	16.00
SHC1206Y-8R2M	8.20	10.90	13.00	9.00	15.00

产品料号 Part NO.	L0 (μH) @100kHz /1.0V	直流电阻 DCR (mΩ)		额定电流 I rms (A)	饱和电流 I sat (A)
		Typ.	Max.	Typ.	Typ.
SHC12065Y-100M	10.00	11.40	15.00	8.00	13.00
SHC12065Y-150M	15.00	18.00	22.00	6.50	12.00
SHC12065Y-220M	22.00	30.00	40.00	6.00	10.00
SHC12065Y-330M	33.00	38.00	53.00	5.00	9.00
SHC12065Y-470M	47.00	50.00	96.00	4.00	6.00
SHC12065Y-680M	68.00	95.50	115.00	3.00	5.50
SHC12065Y-820M	82.00	105.00	126.00	2.50	4.50
SHC12065Y-101M	100.00	98.00	147.00	2.00	4.00

产品料号 Part NO.	L0 (μH) @100kHz /1.0V	直流电阻 DCR (mΩ)		额定电流 I rms (A)	饱和电流 I sat (A)
		Typ.	Max.	Typ.	Typ.
SHC1707Y-2R2M	2.20	2.30	2.70	28.00	40.00
SHC1707Y-4R7M	4.70	3.90	4.70	16.00	26.00
SHC1707Y-6R8M	6.80	5.60	6.90	13.00	23.00
SHC1707Y-8R2M	8.20	7.00	8.40	12.00	22.00
SHC1707Y-100M	10.00	6.95	8.50	10.00	18.00
SHC1707Y-150M	15.00	17.70	22.00	9.00	17.00
SHC1707Y-220M	22.00	20.00	25.00	8.00	15.00
SHC1707Y-330M	33.00	27.00	35.00	6.50	10.00
SHC1707Y-470M	47.00	39.00	47.00	6.00	9.00
SHC1707Y-680M	68.00	67.00	80.00	5.00	8.50
SHC1707Y-820M	82.00	86.00	100.00	4.50	8.00
SHC1707Y-101M	100.00	95.00	125.00	4.00	7.00
SHC1707Y-151M	150.00	135.00	162.00	3.00	5.00
SHC1707Y-351M	350.00	382.00	458.00	2.00	3.50

产品料号 Part NO.	L0 (μH) @100kHz /1.0V	直流电阻 DCR (mΩ)		额定电流 I rms (A)	饱和电流 I sat (A)
		Typ.	Max.	Typ.	Typ.
SHC2213-151M	150.00	68.00	90.00	6.00	8.00
SHC2213-221M	220.00	98.00	130.00	4.50	6.00
SHC2213-401M	400.00	208.00	270.00	4.00	6.00

测试项目 TEST ITEMS	规格要求 SPECIFICATIONS	测试条件/测试方法 TEST CONDITIONS / TEST METHODS
电气特性测试ELECTRICAL PERFORMANCE TEST		
电感量 (L)	参照特性参数表 REFER TO STANDARD ELECTRICAL CHARACTERISTIC LIST.	MICROTEST6377
直流电阻 (DCR)		TH2511
额定电流 (IDC)		加载电流后, 电感量下降不超过30%, 或温升不超过40°C APPLIED THE CURRENT TO COILS THE INDUCTANCE CHANGE SHOULD BE LESS THAN 30% TO INITIAL VALUE AND TEMPERATURE RISE SHOULD NOT BE 40°C TYPICAL
温升测试 TEMPERATURE RISE TEST	温升不超过40°C	加载额定电流, 保持4小时 APPLIED THE ALLOWED DC CURRENT FOR 4 HOURS.
过载测试 OVER LOAD TEST	没有明显的电气损坏 NO EVIDENCE OF ELECTRICAL DAMAGE	加载1.5倍额定电流, 保持5分钟 APPLIED 1.5 TIMES OF RATED ALLOWED DC CURRENT TO INDUCTORS FOR A PERIOD OF 5 MINUTES.
机械特性测试MECHANICAL PERFORMANCE TEST		
耐焊性 SOLDER HEAT RESISTANCE	电感器无外观和电气特性损伤 INDUCTORS SHOULD HAVE NO EVIDENCE OF ELECTRICAL AND MICHANICAL DAMAGE 电感量变化不超过10% INDUCTANCE SHOULD NOT HANGE MORE THAN ±10%	预热: 150°C 100s Max. 焊锡温度SOLDER TEMPERATURE: 255±5°C DIP TIME:10s Max.
振动测试 VIBRATION TEST		振幅: 1.5 mm 频率: 10-55-10HZ / 1 MIN 方向: X, Y, Z 时间: 2 HRS/X, Y, Z
冲击测试 SHOCK TEST		待测品从距离地面1米高自由跌落至3厘米后的木板上, 10次INDUCTORS SHOULD BE DROPPED 10 TIMES FROM A HEIGHT OF 1m ONTO 3cm WOODEN BOARD.
可焊性测试 SOLDERABILITY TEST	超过90%的电极被锡覆盖 MORE THAN 90% OF TERMINAL ELECTRODE SHOULD BE COVERED WITH SOLDER.	预热: 150°C 120s 焊接温度: 255±5°C 时间:10s Max.

环境测试 CLIMATIC TEST

温度特性 TEMPERATURE CHARACTERISTIC	无外观破损 APPEARANCE: NO DAMAGE 电感量变化不超过10% INDUCTANCE: WITHIN $\pm 10\%$ OF INITIAL VALUE.	-45°C ~ +125°C
湿度测试 HUMIDITY TEST		60°C $\pm 2^\circ\text{C}$ / 96 ± 2 小时 R. H: 90-95%RH
低温储存 LOW TEMPERATURE STORAGE		-45°C $\pm 2^\circ\text{C}$ / 24小时 室温静置1小时后测试 Test at room temperature for 1 hour
冷热冲击测试 THERMAL SHOCK TEST		-45 $\pm 2^\circ\text{C}$ 30分钟, +125 $\pm 2^\circ\text{C}$ 30分钟 100次循环 静置2小时后测试
高温储存 HIGH TEMPERATURE STORAGE		125°C $\pm 2^\circ\text{C}$ / 24小时 室温静置1小时后测试 Test at room temperature for 1 hour

包装方式 PACKAGE TYPE:

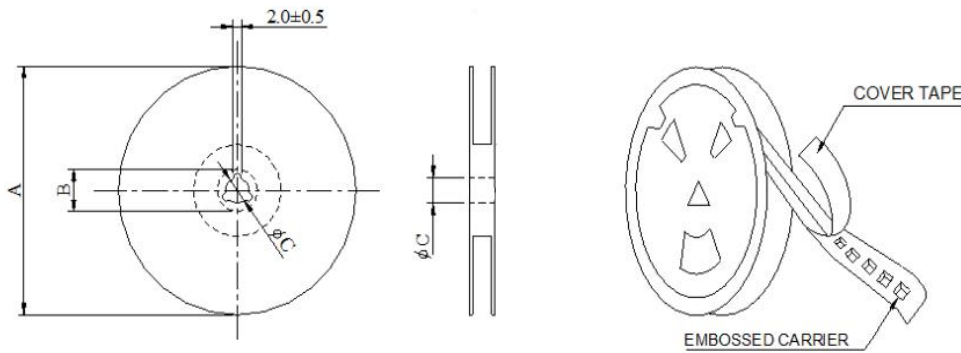

DIMENSIONS (m/m)	
A	330
B	21 ± 0.8
C	13 ± 0.5

TYPE	SHC0503	SHC06024	SHC0603	SHC0605	SHC0805	SHC1004	SHC10045
Quantity (pcs)	2000	2000	1500	1000	1000	1000	1000

TYPE	SHC1005	SHC1204	SHC1205	SHC1206	SHC12065	SHC1707	SHC2213
Quantity (pcs)	800	800	500	500	400	300	100

材料: 透明载带, 透明冷封上带

