

# SPECIFICATION FOR APPROVAL

# 承 认 书

CUSTOMER 客户名称:	NUMBER 编 号: 标准系列
DESCRIPTION 品 名: 贴片电感	QUANTITY 数 量: 10PCS
PART NO. 型 号: 一体成型系列 (羰基粉)	DATE 日 期: 2019/11/19
CUSTOMER PART NO. 客户料号:	NOTE 注 解:

APPROVAL SIGNATURE 客户承认盖章

APPROVED BY 核 准	Q. C. DEPT. 品 管	CHECKED BY 核 查	DRAWN BY 制 作

**产品外观 Product appearance:**



**原理图 Schematic Diagram:**

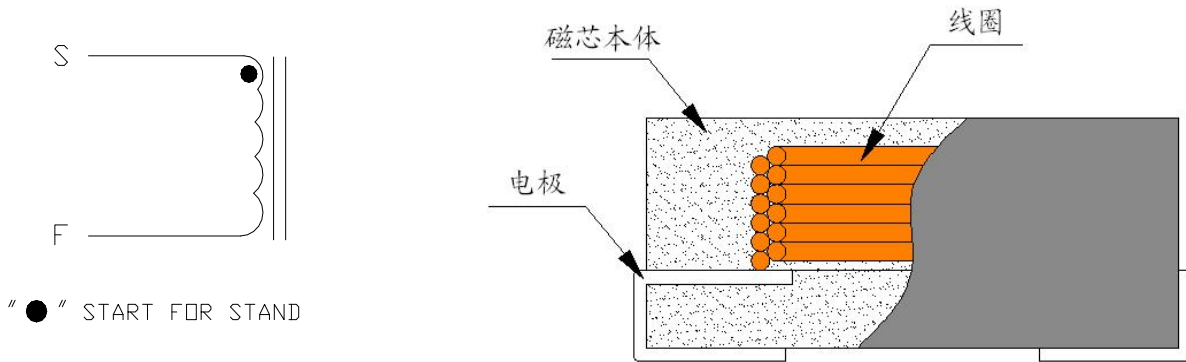

**产品识别 PRODUCT IDENTIFICATION:**

S H C  
↓  
S: SMD  
H: High  
C: Choke

0402  
↓  
外形尺寸:  
4.06\*4.49\*2.0mm

T — 2R2  
↓  
电感量:  
2R2: 2.2UH  
220: 22UH  
221: 220UH  
H: 合金粉  
T: 羰基铁粉  
TF: 羰基不锈钢粉  
Y: 压边, 无Y为平面  
无字母: 还原铁粉

M  
↓  
M: ±20%  
N: ±30%

无字母：还原铁粉

产品系列 PRODUCT SERIES

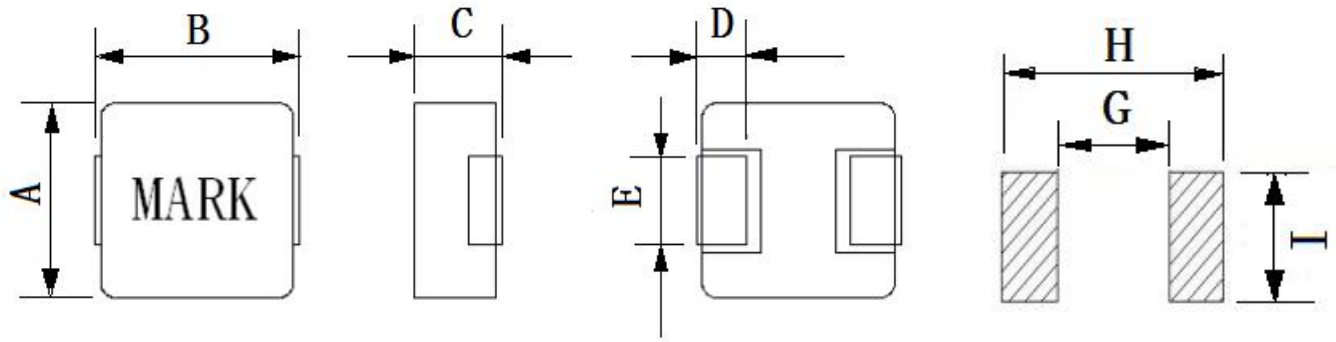

Part No.	A	B	C(Max.)	D	E	G(Ref.)	H(Ref.)	I(Ref.)
SHC0402T	4.06±0.3	4.49±0.4	2.00	1.1±0.3	2.0±0.3	1.75	4.75	2.50
SHC0502T	5.18±0.3	5.49±0.4	2.00	1.2±0.3	2.0±0.3	1.80	5.80	2.50
SHC0503T	5.18±0.3	5.49±0.4	3.00	1.2±0.3	2.0±0.3	1.80	5.80	2.50
SHC0602T	6.6±0.2	7.4 Max.	2.00	1.6±0.3	3.0±0.2	2.50	7.50	3.50
SHC0603T	6.6±0.2	7.4 Max.	3.00	1.6±0.3	3.0±0.2	2.50	7.50	3.50
SHC1004T	10.3±0.3	10.5±1.0	4.00	2.0±0.5	3.0±0.3	4.85	11.85	3.80
SHC2213T	22.0±0.5	22.5±0.5	13.00	5.0±0.5	18.6±0.3	11.56	22.36	18.80

特性参数 Characteristic Data:

产品料号 Part NO.	L0 (μH) @100kHz /1.0V	直流电阻 DCR (mΩ)		额定电流 I <sub>rms</sub> (A)	饱和电流 I <sub>sat</sub> (A)
		Typ.	Max.	Typ.	Typ.
SHC0402T-2R2M	2.20	56.00	70.00	3.00	5.50
SHC0402T-3R3M	3.30	60.00	100.00	2.50	5.00
SHC0402T-4R7M	4.70	115.00	150.00	2.20	4.00
SHC0402T-5R6M	5.60	145.00	173.00	2.00	3.50
SHC0402T-6R8M	6.80	148.00	178.00	1.50	3.00
SHC0402T-8R2M	8.20	241.00	280.00	1.20	2.50
SHC0402T-100M	10.00	278.00	317.00	1.50	2.50

产品料号 Part NO.	L0 (μH) @100kHz /1.0V	直流电阻 DCR (mΩ)		额定电流 I <sub>rms</sub> (A)	饱和电流 I <sub>sat</sub> (A)
		Typ.	Max.	Typ.	Typ.
SHC0502T-R10M	0.10	2.10	2.60	13.00	25.00
SHC0502T-R22M	0.22	4.40	5.30	16.00	26.00
SHC0502T-R33M	0.33	8.40	9.50	7.50	13.00
SHC0502T-R47M	0.47	10.50	13.00	8.00	12.50
SHC0502T-R68M	0.68	14.00	17.00	6.00	12.00
SHC0502T-1R0M	1.00	17.00	19.20	5.00	10.00
SHC0502T-2R2M	2.20	32.00	38.00	4.00	6.00
SHC0502T-3R3M	3.30	58.00	70.00	3.00	4.50
SHC0502T-4R7M	4.70	74.00	96.00	2.80	4.20

SHC0502T-5R6M	5.60	86.00	103.00	2.50	4.20
SHC0502T-6R8M	6.80	114.00	137.00	2.20	4.00
SHC0502T-100M	10.00	135.00	178.00	1.80	3.00

产品料号 Part NO.	L0 (μH) @100kHz /1.0V	直流电阻 DCR (mΩ)		额定电流 I rms (A)	饱和电流 I sat (A)
		Typ.	Max.	Typ.	Typ.
SHC0503T-R22M	0.22	4.00	4.80	20.00	35.00
SHC0503T-R68M	0.68	9.00	11.00	7.00	14.00
SHC0503T-1R0M	1.00	12.00	14.00	6.50	12.00
SHC0503T-1R2M	1.20	11.00	13.00	6.00	10.00
SHC0503T-1R5M	1.50	17.00	20.40	5.50	10.00
SHC0503T-2R2M	2.20	25.00	32.50	5.00	9.00
SHC0503T-3R3M	3.30	33.00	38.00	4.50	8.50
SHC0503T-4R7M	4.70	53.00	64.00	4.00	8.00
SHC0503T-6R8M	6.80	80.00	100.00	4.00	7.00

产品料号 Part NO.	L0 (μH) @100kHz /1.0V	直流电阻 DCR (mΩ)		额定电流 I rms (A)	饱和电流 I sat (A)
		Typ.	Max.	Typ.	Typ.
SHC0602TY-R10M	0.10	2.50	3.50	16.00	30.00
SHC0602TY-R33M	0.33	5.60	6.80	13.00	24.00
SHC0602TY-R47M	0.47	6.40	8.00	10.00	22.00
SHC0602TY-R68M	0.68	10.00	12.70	7.50	14.00
SHC0602TY-1R0M	1.00	16.00	19.20	7.00	12.00
SHC0602TY-1R5M	1.50	26.00	32.00	5.50	10.00
SHC0602TY-2R2M	2.20	32.00	36.00	5.00	9.00
SHC0602TY-3R3M	3.30	65.00	78.00	4.50	8.00
SHC0602TY-4R7M	4.70	73.00	88.00	3.50	5.50
SHC0602TY-6R8M	6.80	114.00	140.00	3.00	5.00
SHC0602TY-100M	10.00	147.00	180.00	2.00	4.00

产品料号 Part NO.	L0 (μH) @100kHz /1.0V	直流电阻 DCR (mΩ)		额定电流 I rms (A)	饱和电流 I sat (A)
		Typ.	Max.	Typ.	Typ.
SHC0603T-R33M	0.33	2.90	3.50	18.00	32.00
SHC0603T-R47M	0.47	3.00	4.20	15.00	26.00
SHC0603T-R68M	0.68	4.80	6.00	14.00	25.00
SHC0603T-R82M	0.82	7.40	8.50	13.00	24.00
SHC0603T-1R0M	1.00	8.50	10.00	12.00	22.00
SHC0603T-1R5M	1.50	9.30	12.00	10.00	18.00
SHC0603T-2R2M	2.20	15.00	20.00	8.00	14.00

SHC0603T-3R3M	3.30	22.00	30.00	6.50	13.00
SHC0603T-4R7M	4.70	30.00	44.00	6.00	10.00
SHC0603T-5R6M	5.60	44.00	50.00	5.00	9.00
SHC0603T-6R8M	6.80	50.00	60.00	4.50	8.00
SHC0603T-100M	10.00	70.00	96.00	3.50	7.00

产品料号 Part NO.	L0 (μH) @100kHz /1.0V	直流电阻 DCR (mΩ)		额定电流 I rms (A)	饱和电流 I sat (A)
		Typ.	Max.	Typ.	Typ.
SHC1004T-R22M	0.22	0.60	0.95	35A	65A
SHC1004T-R33M	0.33	1.10	1.40	32A	63A
SHC1004T-R36M	0.36	1.10	1.40	30A	60A
SHC1004T-R47M	0.47	1.40	1.68	28A	55A
SHC1004T-R56M	0.56	1.70	1.80	27.5A	49A
SHC1004T-R68M	0.68	2.20	2.40	25A	45A
SHC1004T-1R0M	1.00	2.60	3.70	18A	32A
SHC1004T-1R5M	1.50	5.00	5.80	15A	27.5A
SHC1004T-2R2M	2.20	5.70	10.00	12A	27A
SHC1004T-3R3M	3.30	10.50	12.00	11A	20A
SHC1004T-4R7M	4.70	13.50	16.50	10A	17A
SHC1004T-100M	10.00	31.00	40.00	8A	12A
SHC1004T-150M	15.00	53.00	70.00	7A	11A
SHC1004T-220M	22.00	59.00	70.00	4A	7A

产品料号 Part NO.	L0 (μH) @100kHz /1.0V	直流电阻 DCR (mΩ)		额定电流 I rms (A)	饱和电流 I sat (A)
		Typ.	Max.	Typ.	Typ.
SHC2213TY-R47M	0.47	0.56	0.67	80.00	100.00
SHC2213TY-1R0M	1.00	0.86	0.89	69.00	71.00
SHC2213TY-2R2M	2.20	1.22	1.25	58.00	48.00
SHC2213TY-3R3M	3.30	1.50	1.80	49.00	41.00
SHC2213TY-4R7M	4.70	1.77	1.84	47.00	37.00
SHC2213TY-6R8M	6.80	2.84	3.09	36.00	36.00
SHC2213TY-100M	10.00	3.80	4.14	28.00	28.00
SHC2213TY-150M	15.00	5.62	6.11	23.50	24.00
SHC2213TY-220M	22.00	10.6(9.6)	10.8(13)	17.5(30)	16(20)
SHC2213TY-330M	33.00	15.10	15.40	15.50	10.50
SHC2213TY-470M	47.00	17.30	17.70	13.50	10.50
SHC2213TY-750M	75.00	29.76	32.35	12.00	12.00
SHC2213TY-820M	82.00	31.46	34.20	10.20	9.00
SHC2213TY-101M	100.00	36.25	39.40	9.10	7.00

## 电气特性测试ELECTRICAL PERFORMANCE TEST

测试项目 TEST ITEMS	规格要求 SPECIFICATIONS	测试条件/测试方法 TEST CONDITIONS / TEST METHODS
电感量 (L)	参照特性参数表 REFER TO STANDARD ELECTRICAL CHARACTERISTIC LIST.	MICROTEST6377
直流电阻 (DCR)		TH2511
额定电流 (IDC)		加载电流后, 电感量下降不超过30%, 或温升不超过40°C APPLIED THE CURRENT TO COILS THE INDUCTANCE CHANGE SHOULD BE LESS THAN 30% TO INITIAL VALUE AND TEMPERATURE RISE SHOULD NOT BE 40 °C TYPICAL
温升测试 TEMPERATURE RISE TEST	温升不超过40°C	加载额定电流, 保持4小时 APPLIED THE ALLOWED DC CURRENT FOR 4 HOURS.
过载测试 OVER LOAD TEST	没有明显的电气损坏 NO EVIDENCE OF ELECTRICAL DAMAGE	加载1.5倍额定电流, 保持5分钟 APPLIED 1.5 TIMES OF RATED ALLOWED DC CURRENT TO INDUCTORS FOR A PERIOD OF 5 MINUTES.

## 机械特性测试MECHANICAL PERFORMANCE TEST

耐焊性 SOLDER HEAT RESISTANCE	电感器无外观和电气特性损伤 INDUCTORS SHOULD HAVE NO EVIDENCE OF ELECTRICAL AND MICHANICAL DAMAGE  电感量变化不超过10% INDUCTANCE SHOULD NOT HANGE MORE THAN ±10%	预热: 150°C 100s Max.  焊锡温度SOLDER TEMPERATURE: 255 ±5°C  DIP TIME:10s Max.
振动测试 VIBRATION TEST		振幅: 1.5 mm 频率: 10-55-10HZ / 1 MIN  方向: X, Y, Z 时间: 2 HRS/X, Y, Z
冲击测试 SHOCK TEST		待测品从距离地面1米高自由跌落至3厘米后的木板上, 10次INDUCTORS SHOULD BE DROPPED 10 TIMES FROM A HEIGHT OF 1m ONTO 3cm WOODEN BOARD.
可焊性测试 SOLDERABILITY TEST	超过90%的电极被锡覆盖 MORE THAN 90% OF TERMINAL ELECTRODE SHOULD BE COVERED WITH SOLDER.	预热: 150°C 120s 焊接温度: 255 ±5°C 时间:10s Max.

## 环境测试 CLIMATIC TEST

温度特性 TEMPERATURE CHARACTERISTIC	无外观破损 APPEARANCE:NO DAMAGE  电感量变化不超过10% INDUCTANCE:WITHIN±10% OF INITIAL VALUE.	-45°C ~ +125°C
湿度测试 HUMIDITY TEST		60°C±2°C / 96±2 小时 R.H:90-95%RH
低温储存 LOW TEMPERATURE STORAGE		-45°C±2°C / 24小时 室温静置1小时后测试 Test at room temperature for 1 hour
冷热冲击测试 THERMAL SHOCK TEST		-45±2°C 30分钟, +125±2°C 30分钟 100次循环 静置2小时后测试
高温储存 HIGH TEMPERATURE STORAGE		125°C±2°C / 24小时 室温静置1小时后测试 Test at room temperature for 1 hour

## 包装方式 PACKAGE TYPE:

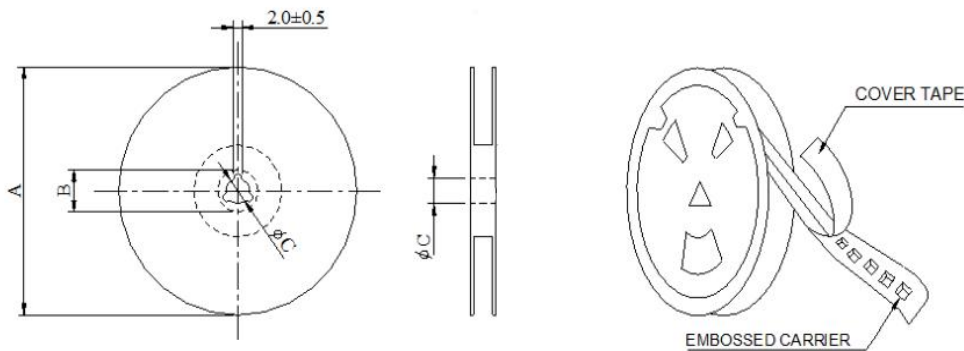

DIMENSIONS (m/m)	
A	330
B	21±0.8
C	13±0.5

TYPE	SHC0402T	SHC0502T	SHC0503T	SHC0602T	SHC0603T	SHC1004T	SHC2213T
Quantity (pcs)	3000	3000	2000	2000	1500	1000	100

材料: 透明载带, 透明冷封上带

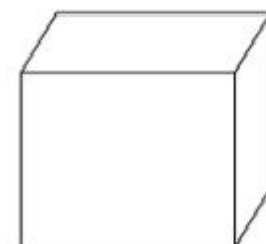
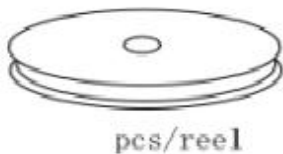

middle carton/big carton