

SPECIFICATION FOR APPROVAL

承 认 书

CUSTOMER

客户名称:

NUMBER

编 号: 标准

DESCRIPTION

品 名: 贴片共模滤波器

QUANTITY

数 量:

PART NO.

型 号: BCDF系列

DATE

日 期:

CUSTOMER PART NO.

客户料号:

NOTE

注 解:

APPROVAL SIGNATURE 客户承认签章

APPROVED BY 核 准	Q. C. DEPT. 品 管	CHECKED BY 核 查	DRAWN BY 制 作

INTRODUCTION AND CHARACTERISTICS

INTRODUCTION

The BCDF series is effective for common mode noise suppression in differential signal. A full series of common mode choke is designed for excellent noise attenuation with compact sizing for use in wide range of applications.



CHARACTERISTICS

- Excellent solderability and high heat resistance for reflow soldering or wave soldering
- Miniature size, suitable for SMT
- With large coupling coefficient, little impact on high-speed differential signal
- Prevention of common mode noise at high frequency

APPLICATIONS

- USB lines of PC, peripheral equipments
- LVDS lines of notebook PC, LCD
- Redundant noise suppression on digital product clock lines, signal lines and suppression noise on circuit

Part Number System

BCDF 1608 -2 -900 T

① ② ③ ④ ⑤

① Type:BCDF

③ Number of Lines: 2

⑤ Packing:Tape & Reel

② External Dimensions (L×W) (mm):1.6×0.8

④ Impedance:900=90Ω

SHAPE AND DIMENSIONS

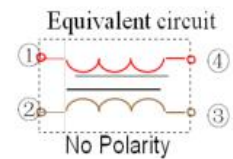
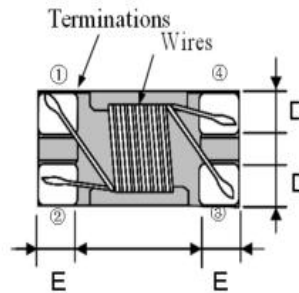
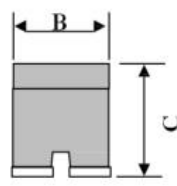
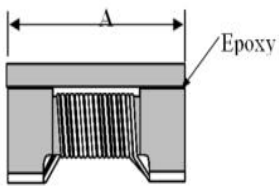

Unit:mm

SIZE	A	B	C	D Typ	E Typ
BCDF1210(0504)	1.2±0.2	1.0±0.2	0.8±0.1	0.36	0.33
BCDF1608(0603)	1.6±0.1	0.8±0.1	1.1±0.1	0.25	0.33
BCDF2012(0805)	2.0±0.2	1.2±0.2	1.2±0.2	0.40	0.45
BCDF3216(1206)	3.2±0.2	1.6±0.2	1.8±0.2	0.60	0.60
BCDF3225(1210)	3.2±0.2	2.5±0.2	2.2±0.2	0.8	0.65
BCDF4532(1812)	4.5±0.2	3.2±0.2	2.8±0.2	1.20	1.00

SPECIFICATIONS

BDCF1210(0504) TYPE

part Number	Common Mode Impedance @100MHz	Insulation Resistance	DC Resistance	Rated Current	Rated Voltage
Units	$\Omega \pm 25\%$	M Ω (Min)	Ω (Max)	mA (Max)	V (Max)
Symbol	Z	IR	DCR	Ir	Vdc
BCDF1210-2-670T	67	10	0.40	300	50
BCDF1210-2-900T	90	10	0.50	280	50
BCDF1210-2-121T	120	10	0.55	270	50
BCDF1210-2-161T	160	10	0.58	260	50
BCDF1210-2-181T	180	10	0.60	260	50
BCDF1210-2-251T	250	10	0.70	230	50
BCDF1210-2-331T	330	10	0.80	200	50

BDCF1608(0603) TYPE

part Number	Common Mode Impedance @100MHz	Insulation Resistance	DC Resistance	Rated Current	Rated Voltage
Units	$\Omega \pm 25\%$	M Ω (Min)	Ω (Max)	mA (Max)	V (Max)
Symbol	Z	IR	DCR	Ir	Vdc
BCDF1608-2-670T	67	10	0.30	300	50
BCDF1608-2-900T	90	10	0.30	300	50
BCDF1608-2-121T	120	10	0.36	250	50
BCDF1608-2-161T	160	10	0.40	200	50
BCDF1608-2-221T	220	10	0.42	200	50

BDCF2012(0805) TYPE

part Number	Common Mode Impedance @100MHz	Insulation Resistance	DC Resistance	Rated Current	Rated Voltage
Units	$\Omega \pm 25\%$	M Ω (Min)	Ω (Max)	mA (Max)	V (Max)
Symbol	Z	IR	DCR	Ir	Vdc
BCDF2012-2-300T	30	10	0.20	450	50
BCDF2012-2-400T	40	10	0.20	450	50
BCDF2012-2-670T	67	10	0.25	400	50
BCDF2012-2-750T	75	10	0.30	400	50
BCDF2012-2-900T	90	10	0.30	400	50
BCDF2012-2-121T	120	10	0.30	350	50
BCDF2012-2-161T	160	10	0.30	340	50
BCDF2012-2-181T	180	10	0.35	330	50
BCDF2012-2-201T	200	10	0.35	330	50
BCDF2012-2-221T	220	10	0.35	330	50
BCDF2012-2-261T	260	10	0.40	300	50
BCDF2012-2-371T	370	10	0.40	280	50
BCDF2012-2-601T	600	10	0.55	250	50
BCDF2012-2-671T	670	10	0.60	150	50
BCDF2012-2-901T	900	10	0.80	120	50
BCDF2012-2-102T	1000	10	0.80	100	50
BCDF2012-2-222T	2200	10	1.40	100	50

BDCF3216(1206) TYPE

part Number	Common Mode Impedance @100MHz	Insulation Resistance	DC Resistance	Rated Current	Rated Voltage
Units	$\Omega \pm 25\%$	M Ω (Min)	Ω (Max)	mA (Max)	V (Max)
Symbol	Z	IR	DCR	Ir	Vdc
BCDF3216-2-670T	67	10	0.25	400	50
BCDF3216-2-750T	75	10	0.30	400	50
BCDF3216-2-900T	90	10	0.30	400	50
BCDF3216-2-101T	100	10	0.30	380	50
BCDF3216-2-121T	120	10	0.35	370	50
BCDF3216-2-161T	160	10	0.40	340	50
BCDF3216-2-181T	180	10	0.40	340	50
BCDF3216-2-261T	260	10	0.50	310	50
BCDF3216-2-281T	280	10	0.50	310	50
BCDF3216-2-361T	360	10	0.50	280	50
BCDF3216-2-371T	370	10	0.50	280	50
BCDF3216-2-431T	430	10	0.60	280	50
BCDF3216-2-601T	600	10	0.80	260	50
BCDF3216-2-102T	1000	10	1.00	230	50
BCDF3216-2-222T	2200	10	1.20	200	50

BDCF3225(1210) TYPE

part Number	Common Mode Impedance @100MHz	Insulation Resistance	DC Resistance	Rated Current	Rated Voltage
Units	$\Omega \pm 25\%$	M Ω (Min)	Ω (Max)	mA (Max)	V (Max)
Symbol	Z	IR	DCR	Ir	Vdc
BCDF3225-2-800T	80	10	0.15	2000	50
BCDF3225-2-900T	90	10	0.15	2000	50
BCDF3225-2-121T	120	10	0.18	2000	50
BCDF3225-2-601T	600	10	0.25	1000	50
BCDF3225-2-102T	1000	10	0.35	1200	50

BDCF4532(1812) TYPE

part Number	Common Mode Impedance @100MHz	Insulation Resistance	DC Resistance	Rated Current	Rated Voltage
Units	$\Omega \pm 25\%$	M Ω (Min)	Ω (Max)	mA (Max)	V (Max)
Symbol	Z	IR	DCR	Ir	Vdc
BCDF4532-2-800T	80	10	0.07	3000	50
BCDF4532-2-900T	90	10	0.07	3000	50
BCDF4532-2-121T	120	10	0.07	3000	50
BCDF4532-2-601T	600	10	0.3	1000	50
BCDF4532-2-102T	1000	10	0.4	800	50
BCDF4532-2-142T	1400	10	0.5	700	50

TYPICAL ELECTRICAL CHARACTERISTICS 典型电气特性

COMMON MODE & DIFFERENTIAL MODE vs. FREQUENCY

BCDF1210-2-670T

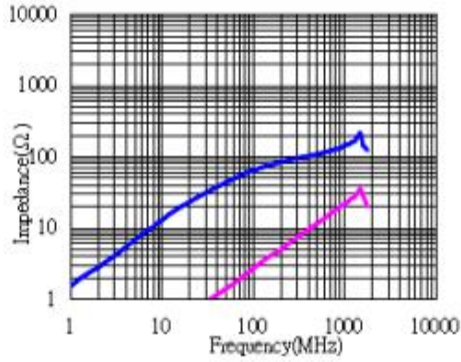

BCDF1210-2-900T

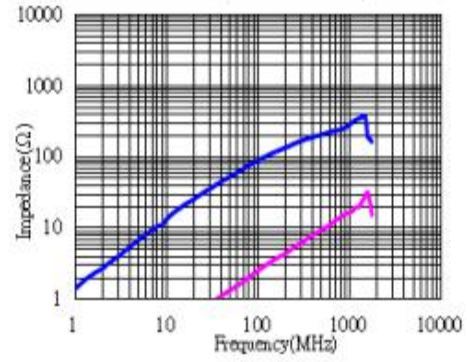

BCDF1210-2-121T

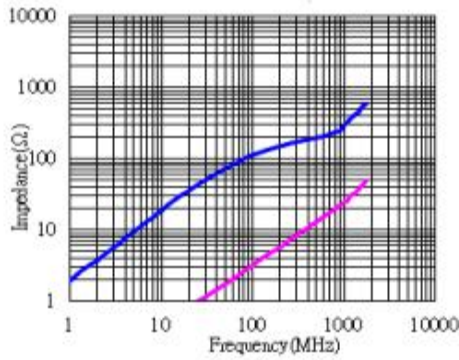

BCDF1210-2-161T

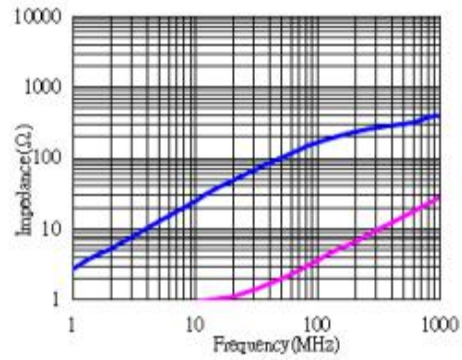

BCDF1210-2-181T

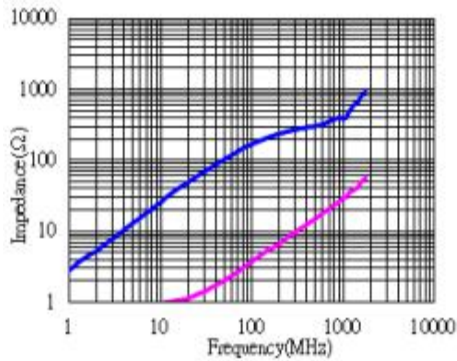

BCDF1210-2-251T

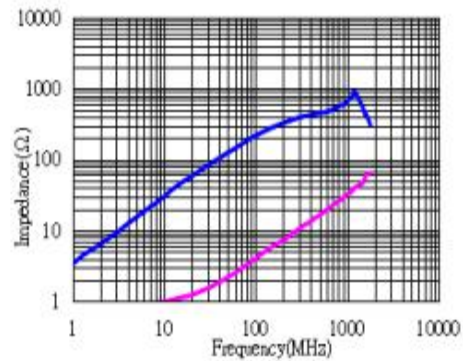

BCDF1210-2-331T

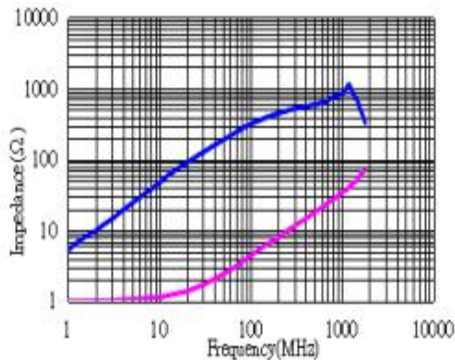

BCDF1608-2-670T

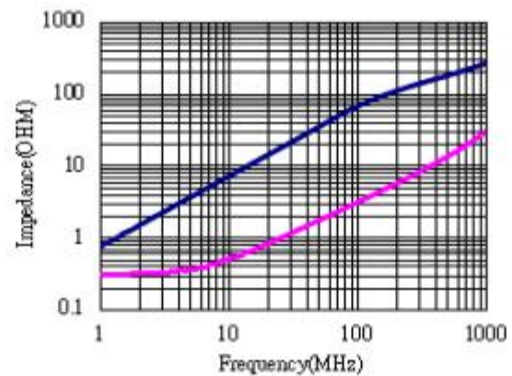

BCDF1608-2-900T

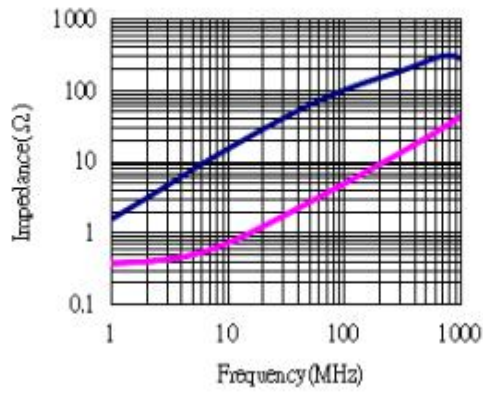

BCDF1608-2-121T

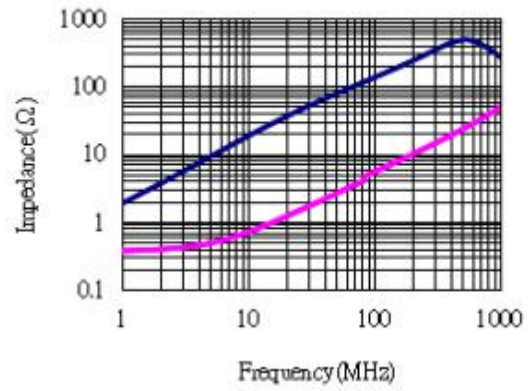

BCDF1608-2-161T

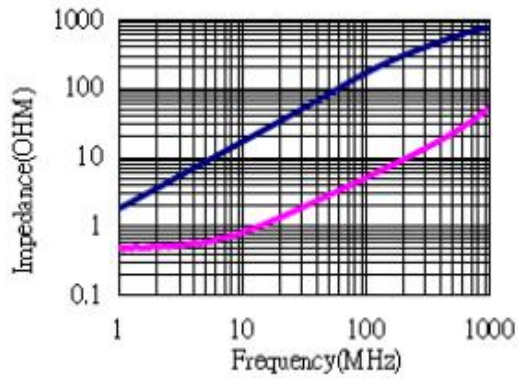

BCDF1608-2-221T

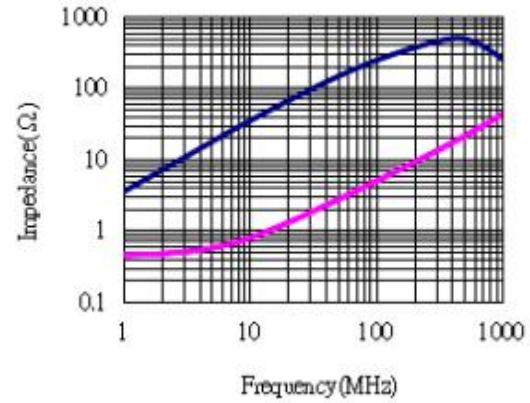

BCDF2012-2-670T

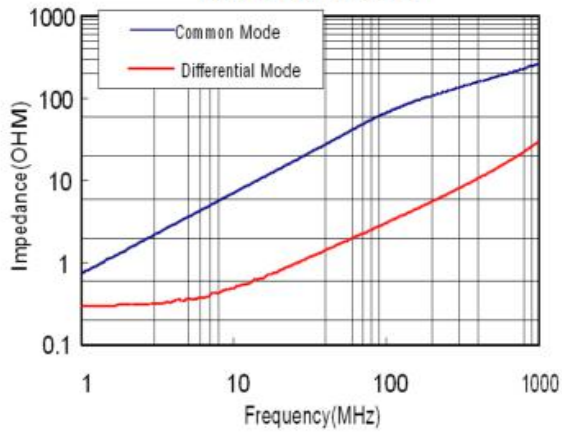

BCDF2012-2-121T

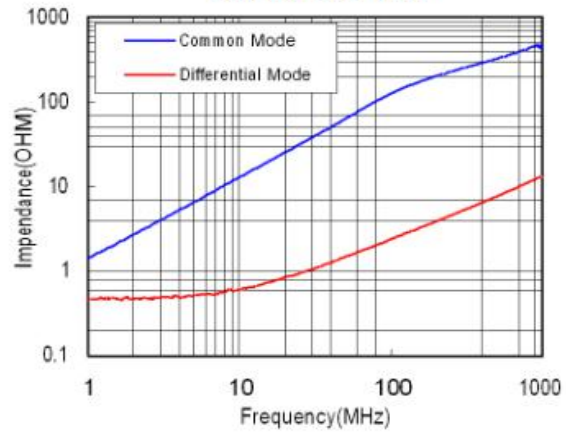

BCDF2012-2-201T

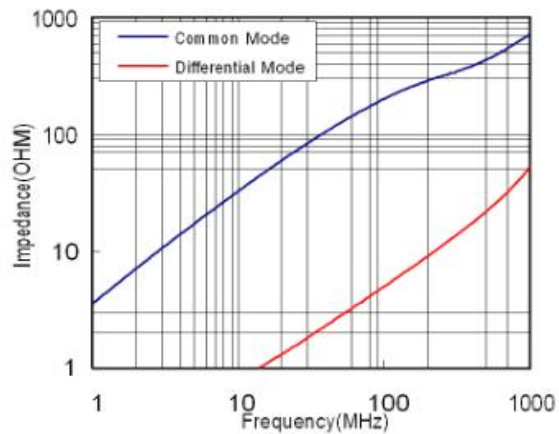

BCDF2012-2-261T

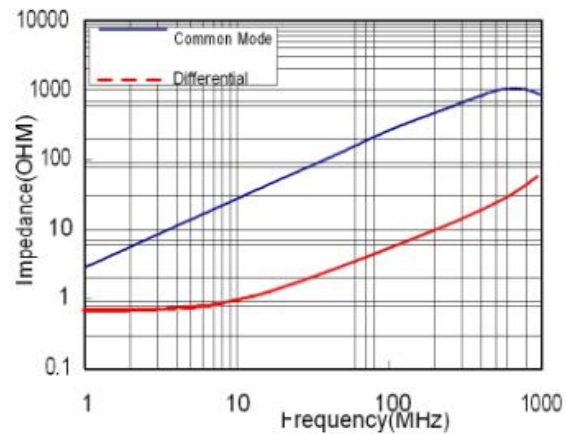

BCDF2012-2-371T

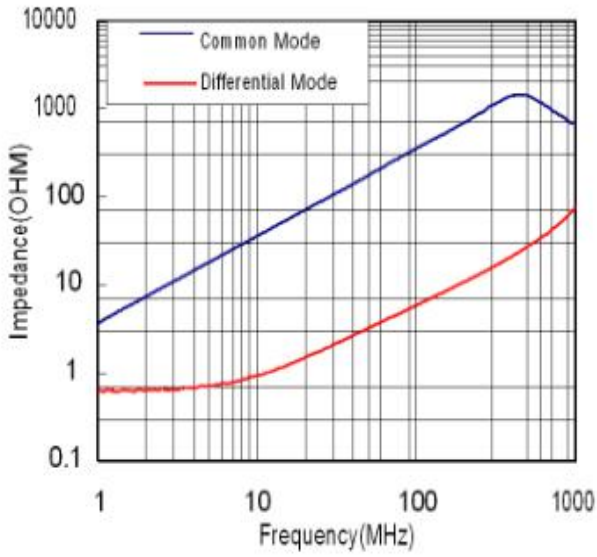

BCDF2012-2-601T

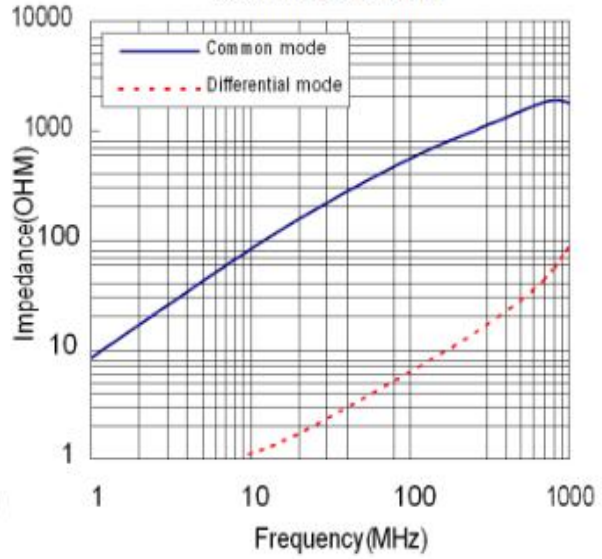

BCDF3216-2-900T

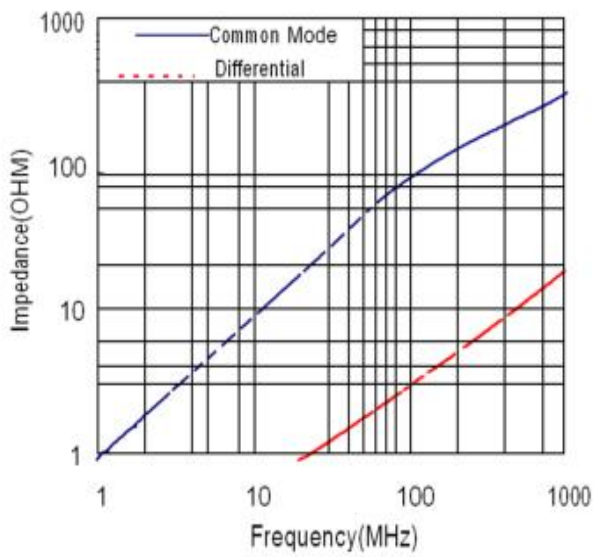

BCDF3216-2-601T

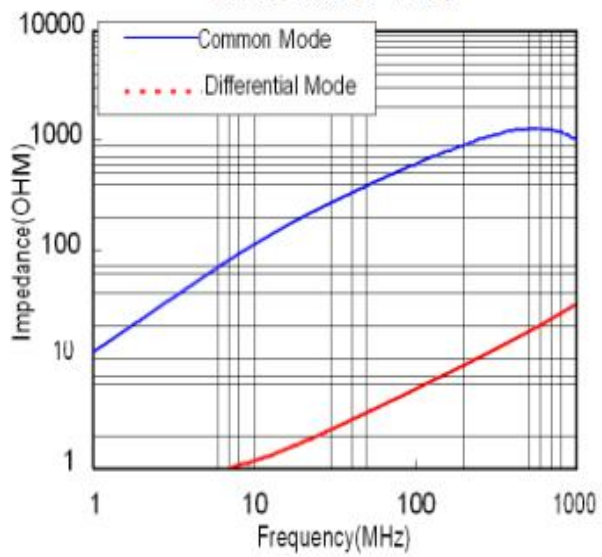

BCDF3216-2-102T

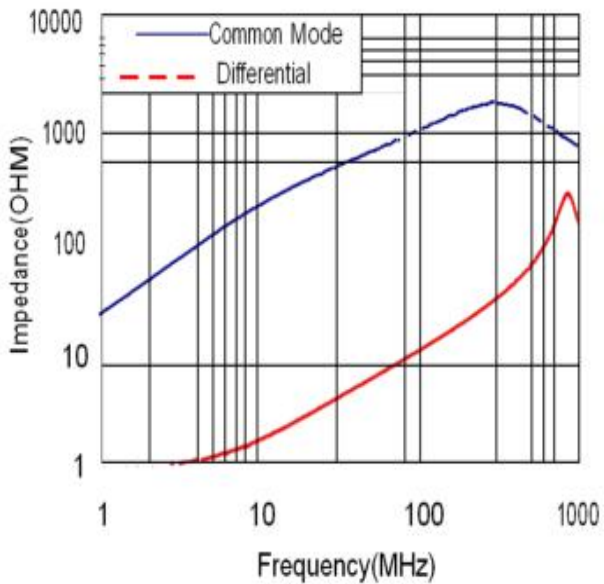

BCDF3216-2-222T

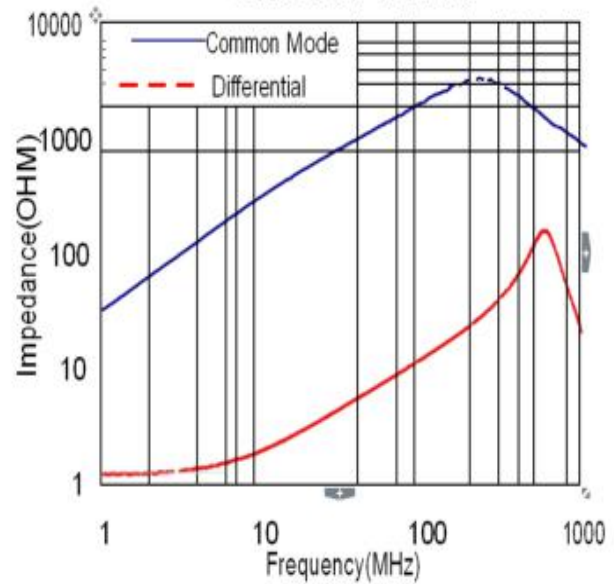

BCDF3225-2-800T

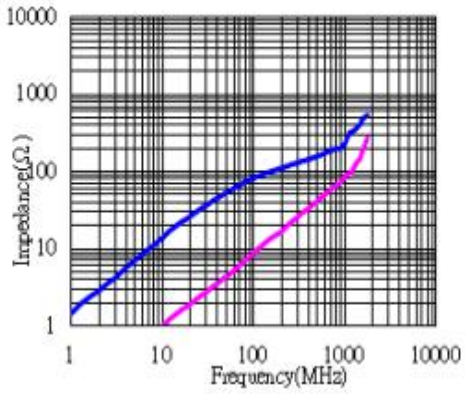

BCDF3225-2-900T

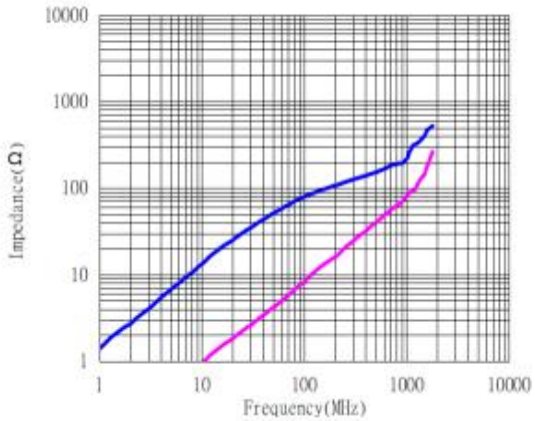

BCDF3225-2-121T

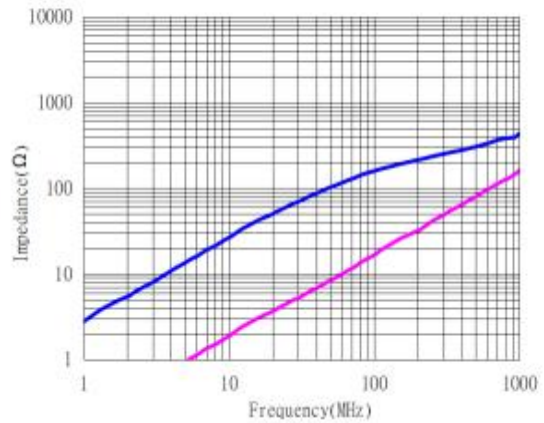

BCDF3225-2-601T

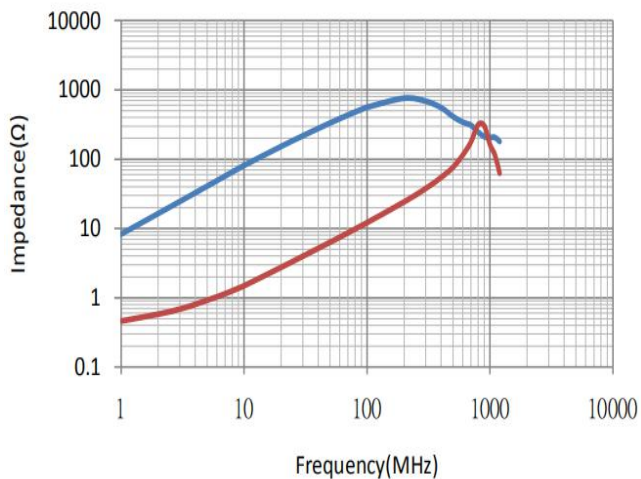

BCDM3225-2-102T

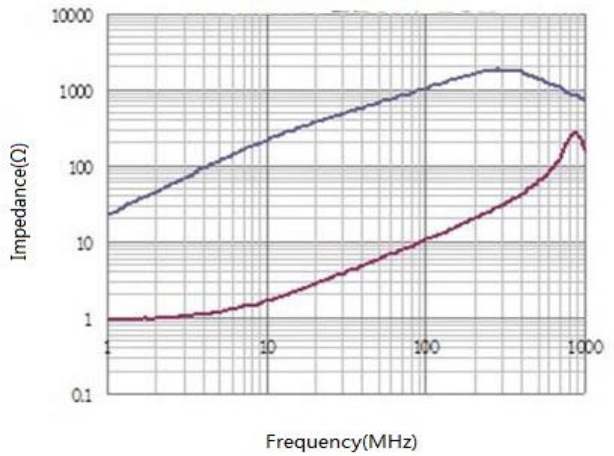

Frequency(MHz)

BCDF4532-2-800T

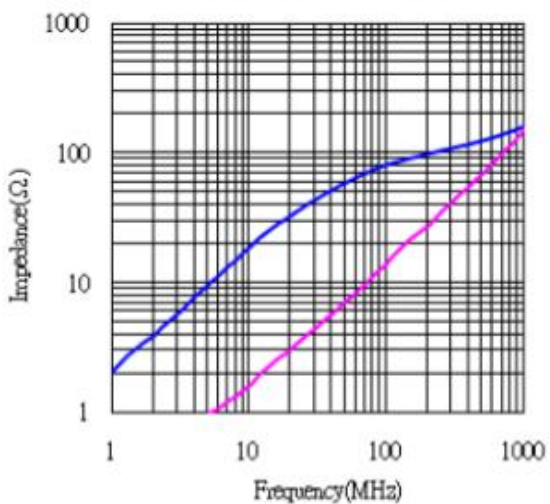

BCDF4532-2-900T

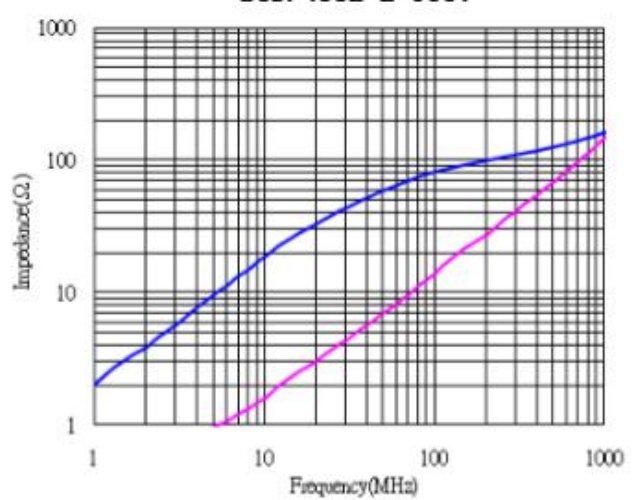

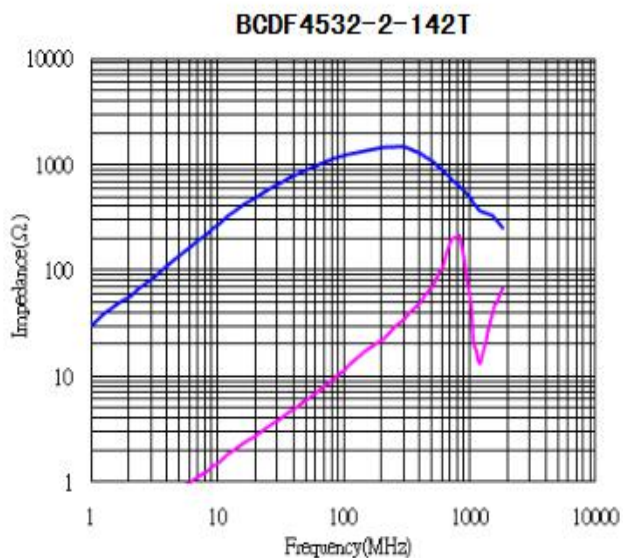
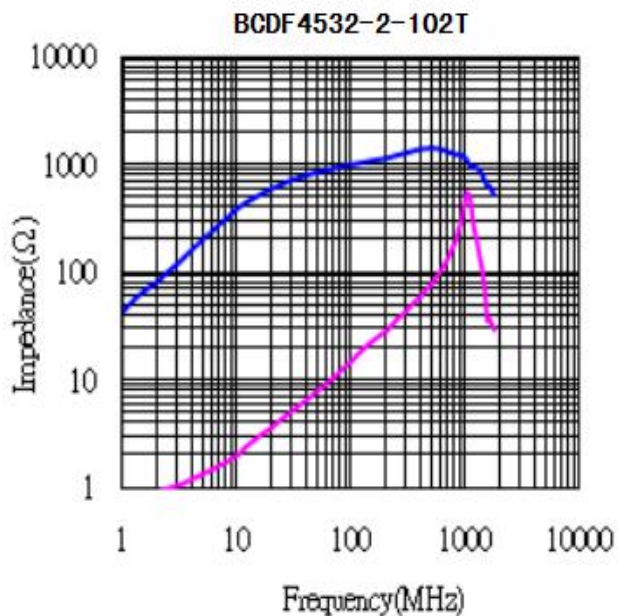

Packaging Style 包装

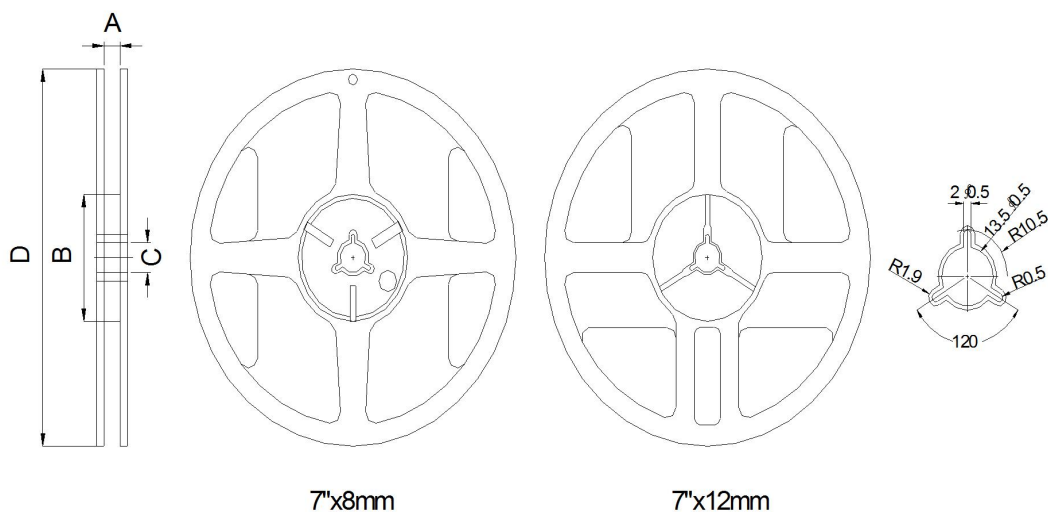

Type	A(mm)	B(mm)	C(mm)	D(mm)
7"x8mm	9.0±0.5	60±2	13.5±0.5	178±2
7"x12mm	13.5±0.5	60±2	13.5±0.5	178±2

Dimension	1210	1608	2012	3216	3225	4532
Per Reel (pcs)	1000	2000	2000	2000	1000	500