

SPECIFICATION FOR APPROVAL

承认书

CUSTOMER

客户名称:

NUMBER

编号:

DESCRIPTION

品名: 贴片共模滤波器

QUANTITY

数量:

PART NO.

型号: BCDCM1513-2-701TA

DATE

日期:

CUSTOMER PART NO.

客户料号:

NOTE

注解:

APPROVAL SIGNATURE 客户承认签章

APPROVED BY 核准	Q. C. DEPT. 品管	CHECKED BY 核查	DRAWN BY 制作

BCDCM1513-2-701TA

DC COMMON MODE FILTER

FEATURES

- A chip-type common mode filter for large current applications. Common mode impedance surpasses 500Ω at 100MHz. Noise is greatly suppressed.
- Capable of handling the highest current(up to 10A) of any chip-type common mode filter.
- Height and size have been considered ,resulting in a compact and light-weight choke coil.Applicable for the miniaturization required to reduce the size and weight of portable equipment.
- The products contain no lead and also support lead-free soldering.
- The product does not contain regulatde substances that are slated to be included in ROHS.



APPLICATIONS

Used for power line noise suppression for any electronic-devices
Used to counter adapter/battery line noise for relatively large electronic devices such as notebook PCs, stand-alone word processors, etc

TEMPERATURE RANGES

Operating	-40to+125°C
Storage (After mount)	-40to+125°C

Part Number System

BCDCM 1513 -2 -701 T A

① ② ③ ④ ⑤ ⑥

- ① Type:BCDCM
- ② External Dimensions(L×W) (mm) :15*13
- ③ Number of Lines: 2
- ④ Impedance:701=700 Ω
- ⑤ Packing:Tape & Reel
- ⑥ Management Symbol:A

ELECTRICAL CHARACTERISTICS

Part No.	Impedance(Ω) [at 100MHz]		DC resistance	Rated current	Insulation resistance
	min	TYP	(mΩ) max [1 line]	Idc (A) max	(MΩ) min
BCDCM1513-2-701TA	500	700	6	10	10

BCDCM1513-2-701TA

DC COMMON MODE FILTER

TYPICAL ELECTRICAL CHARACTERISTICS

IMPEDANCE vs. FREQUENCY CHARACTERISTICS

BCDCM1513-2-701TA

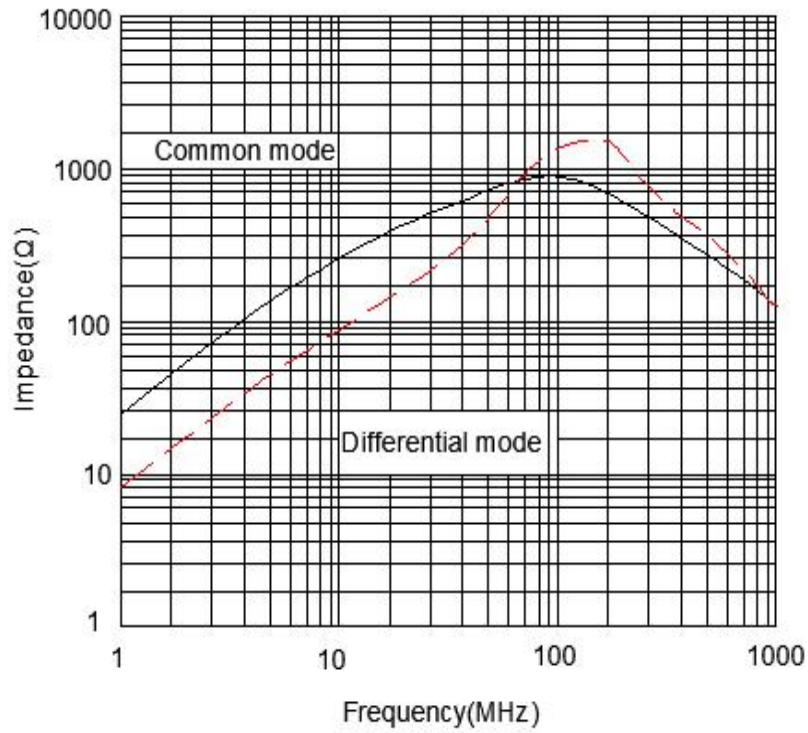

BCDCM1513-2-701TA

DC COMMON MODE FILTER

SHAPES AND DIMENSIONS/CIRCUIT DIAGRAM/RECOMMENDED
PC BOARD PATTERN (REFLOW SOLDERING)

◆ Dimensions (mm)

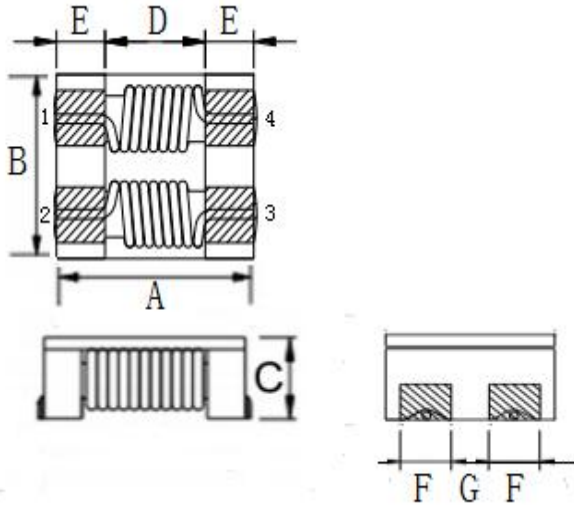

- UNIT: mm
- A: 15.0 ± 0.5
 - B: 13.0 ± 0.5
 - C: 7.5 (MAX)
 - D: 9.0 E: 3.0
 - F: 3.1 ± 0.1
 - G: 3.7 ± 0.6

◆ Land Pattern (mm)

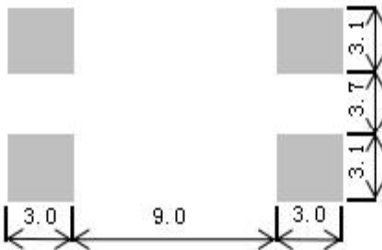

◆ Schematics (Bottom)

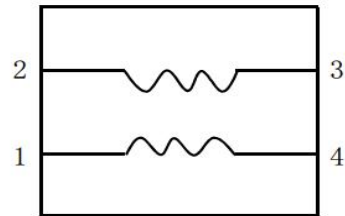

No polarity

BCDCM1513-2-701TA

DC COMMON MODE FILTER

Recommended Reflow Temperature Curve

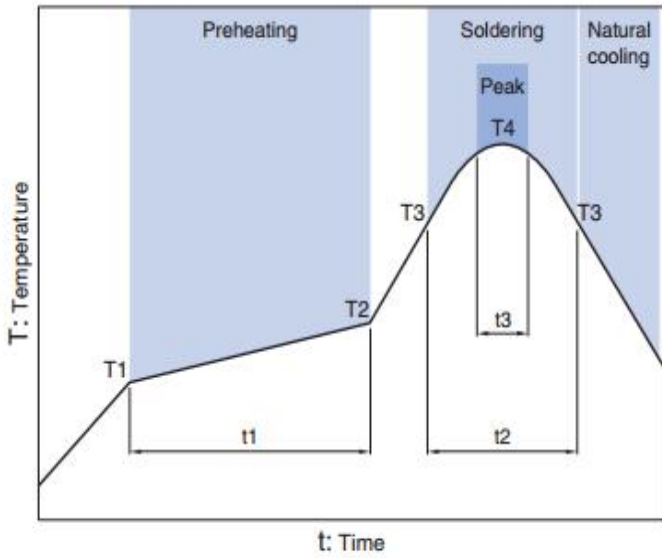

Preheating			Soldering		Peak	
Temp.	Temp.	Time	Temp.	Time	Temp.	Time
T1	T2	t1	T3	t2	T4	t3
150°C	180°C	60 to 120s	230°C	10 to 30s	245°C	5s

Package size (mm)

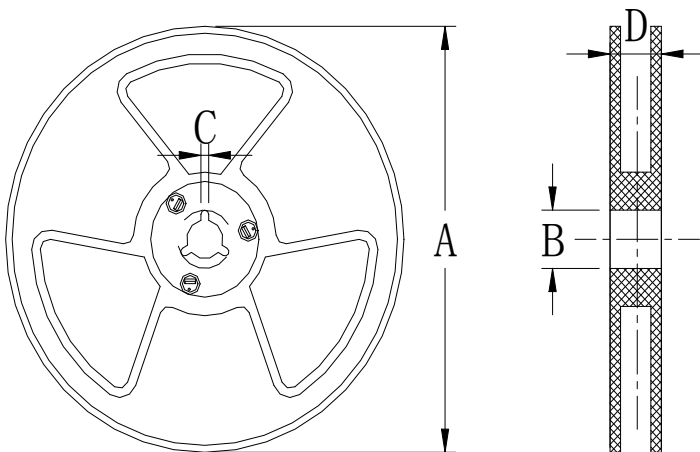

size	Specs	13"	7"
	A		Φ 330±2.0
B		Φ 90 ± 2.0	
C		2.3	
D		21.5	