

SPECIFICATION FOR APPROVAL

承 认 书

CUSTOMER

客户名称:

NUMBER

编 号: Y-21070301

DESCRIPTION

品 名: 贴片共模电感

QUANTITY

数 量: 10pcs

PART NO.

型 号: BCDM1711-2-682T

DATE

日 期: 2021/7/3

CUSTOMER PART NO.

客户料号:

NOTE

注 解:

APPROVAL SIGNATURE
客户承认签章

| APPROVED BY 核 准 | Q. C. DEPT. 品 管 | CHECKED BY 核 查 | DRAWN BY 制 作 |
|--------------------|--------------------|-------------------|-----------------|
| | | | |

| | | | |
|----------------|--|-----------------|-----------------|
| 客户 CUSTOMER | | 规格型号 PART NO | BCDM1711-2-682T |
|----------------|--|-----------------|-----------------|

1: 外形尺寸: (单位: mm)

OVERALLDIMESSON (UNIT:mm)

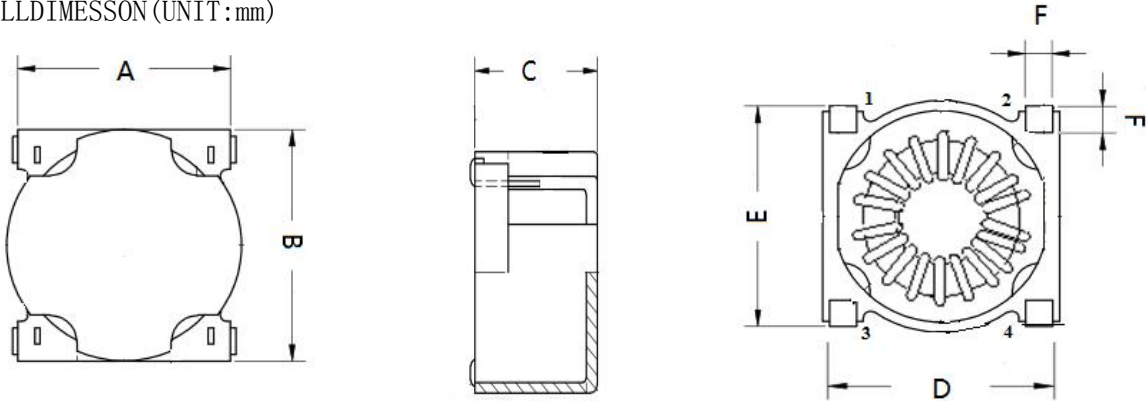

| 尺寸 | A | B | C | D | E | F |
|------|----------|----------|----------|----------|----------|--------|
| 单位mm | 15.8±0.5 | 17.5±0.5 | 11.5 MAX | 16.5±0.5 | 16.6±0.5 | 2.0Ref |

2: 接线图: 两组线分绕

WIRING DIAGRAM: SEPARATE WINDING

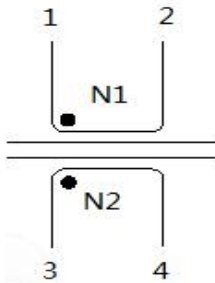

No polarity

3: 焊接尺寸: mm

WELDING DIMENSION: mm

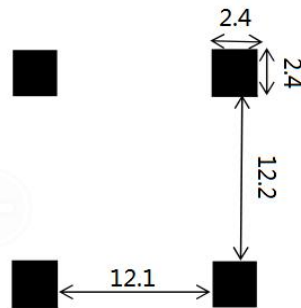

4: 电气性能参数(ELECTRICAL PARAMETERS)

| | |
|---------------------------|---------------------|
| 电感量及允许偏差 (1KHz/ 0.25V) | L12=L34: 6.8mH(MIN) |
| 直流电阻 DC RESISTANCE | 240 mΩ (MAX) |
| 额定电流 RATED CURRENT | 0.8A MAX |
| 阻抗(0.6MHz) IMPEDANCE | 12000 Ω MIN |

测试仪表 (MEASUREMENT INSTRUMENT):

HM2791 HM2801 HP4285
CH19073

在最坏情况下建议零件的温度不超过+125° C。(It is recommended that the temperature of the part does not exceed +125° C under worst case conditions.)

贮存环境(Storage conditions):存放环境温度-20° C至60° C,相对湿度不高于70%,并存放在不含硫和氯的空气气氛中(请不要直接暴露在阳光下) Storage ambient temperature-20 ° C to 60 ° C, 70%RH or less, and isolate the parts from sulphic and chloric atm osphere. (Please don't expose to the sun directly)

| | |
|-------|----------------------------------|
| Note: | SPEC. NO. : Y-21070301 1/2 |
|-------|----------------------------------|

| | | | |
|----------------|--|-----------------|-----------------|
| 客户 CUSTOMER | | 规格型号 PART NO | BCDM1711-2-682T |
|----------------|--|-----------------|-----------------|

零件工作温度(Operating temperature of parts): -40° C - 125° C

温升(Temperature Rise) : < 55K

电性能试验条件(Est conditions of Electrical Properties) : 20° C、相对湿度33%
(20° C, 33% RH)

没有特殊规定下(If not specified differently)

5: 阻抗曲线图(IMPEDANCE CURVE)

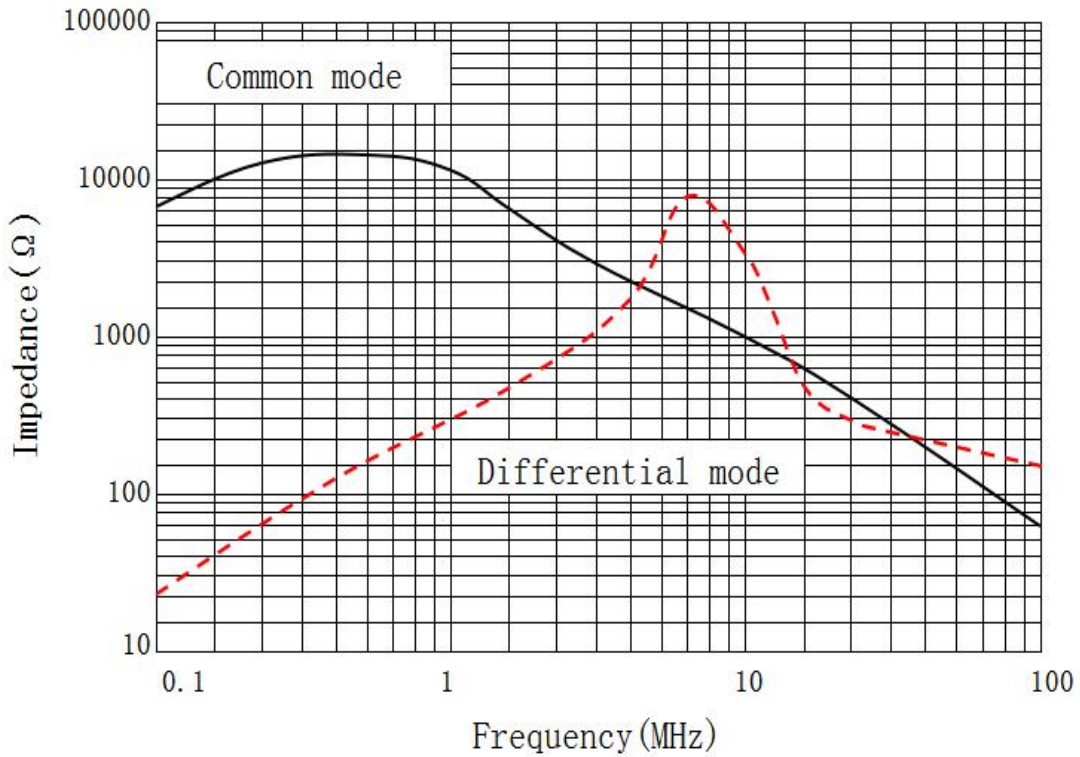

6: 包装(PACKING)

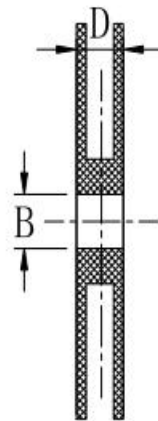
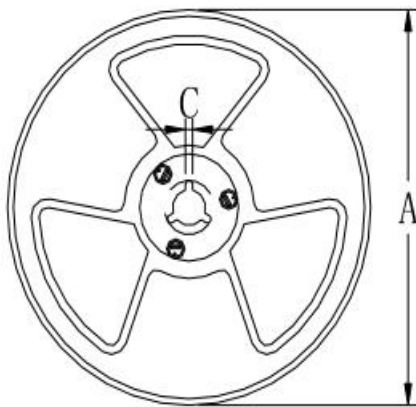

| 规格 尺寸 | 13" | 7" |
|----------|-----------|-----------|
| A | Φ 330±2.0 | Φ 178±2.0 |
| B | Φ90±2.0 | |
| C | 2.3 | |
| D | 30.5 | |

| | |
|-------|----------------------------------|
| Note: | SPEC. NO. : Y-21070301 2/2 |
|-------|----------------------------------|