

SPECIFICATION FOR APPROVAL

承 认 书

CUSTOMER

客户名称:

NUMBER

编 号: Y-21070202

DESCRIPTION

品 名: 贴片共模电感

QUANTITY

数 量: 10pcs

PART NO.

型 号: BCDM116-2-152T

DATE

日 期: 2021-7-2

CUSTOMER PART NO.

客户料号:

NOTE

注 解:

APPROVAL SIGNATURE

客户承认签章

| APPROVED BY 核 准 | Q. C. DEPT. 品 管 | CHECKED BY 核 查 | DRAWN BY 制 作 |
|--------------------|--------------------|-------------------|-----------------|
| | | | |

| | | | |
|----------------|--|-----------------|----------------|
| 客户 CUSTOMER | | 规格型号 PART NO | BCDM116-2-152T |
|----------------|--|-----------------|----------------|

1: 外形尺寸: (单位: mm)

OVERALLDIMESSON (UNIT: mm)

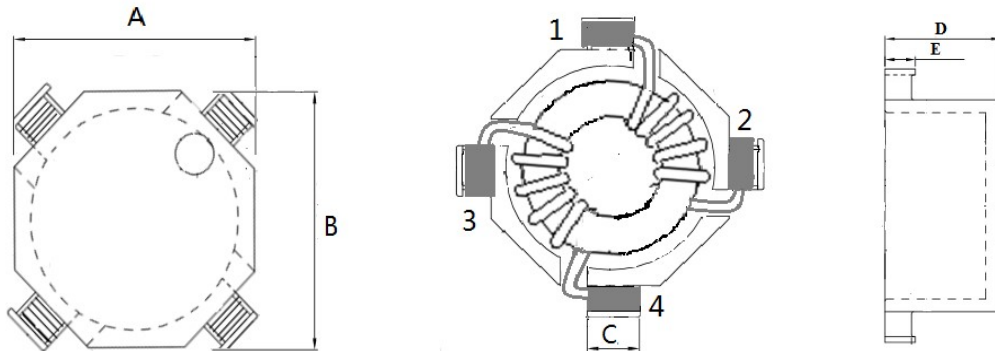

| | | | | | |
|------|----------|----------|--------|--------|---------|
| 尺寸 | A | B | C | D | E |
| 单位mm | 11.7±0.3 | 11.7±0.3 | 2.3typ | 6.5MAX | 1.6±0.3 |

2: 接线图: 两组线分绕

WIRING DIAGRAM: SEPARATE WINDING

3: 焊接尺寸: mm

WELDING DIMENSION: mm

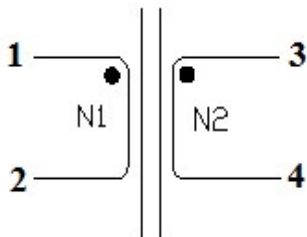

No polarity

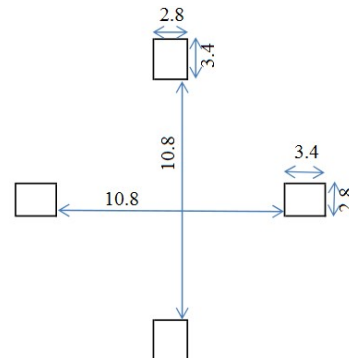
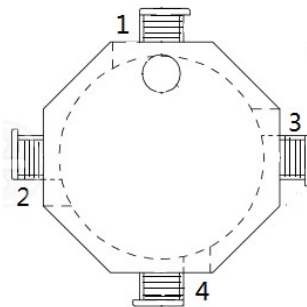

4: 电气性能参数(ELECTRICAL PARAMETERS)

| | |
|---------------------------|---------------------|
| 电感量及允许偏差 (1KHz/ 0.25V) | L12=L34: 1.5mH(MIN) |
| 直流电阻 DC RESISTANCE | 130 mΩ (MAX) |
| 额定电流 RATED CURRENT | 1.2A MAX |
| 阻抗(5MHz) IMPEDANCE | 2400 Ω MIN |

测试仪表 (MEASUREMENT INSTRUMENT):

HM2791 HM2801 HP4285
CH19073

在最坏情况下建议零件的温度不超过+125° C。(It is recommended that the temperature of the part does not exceed +125° C under worst case conditions.)

贮存环境(Storage conditions):存放环境温度-20° C至60° C,相对湿度不高于70%,并存放在不含硫和氯的空气气氛中(请不要直接暴露在阳光下) Storage ambient temperature-20° C to 60° C, 70%RH or less, and isolate the parts from sulphic and chloric atm osphere. (Please don't expose to the sun directly)

| | |
|-------|---------------------------|
| Note: | SPEC. NO. : Y-21070201 |
|-------|---------------------------|

| | | | |
|----------------|--|-----------------|----------------|
| 客户 CUSTOMER | | 规格型号 PART NO | BCDM116-2-152T |
|----------------|--|-----------------|----------------|

零件工作温度(Operating temperature of parts): $-40^{\circ}\text{C} - 125^{\circ}\text{C}$

温升 (Temperature Rise) : $< 55\text{K}$

电性能试验条件 (Est conditions of Electrical Properties) : 20°C 、相对湿度33% (20°C , 33% RH)

没有特殊规定下 (If not specified differently)

5: 阻抗曲线图 (IMPEDANCE CURVE)

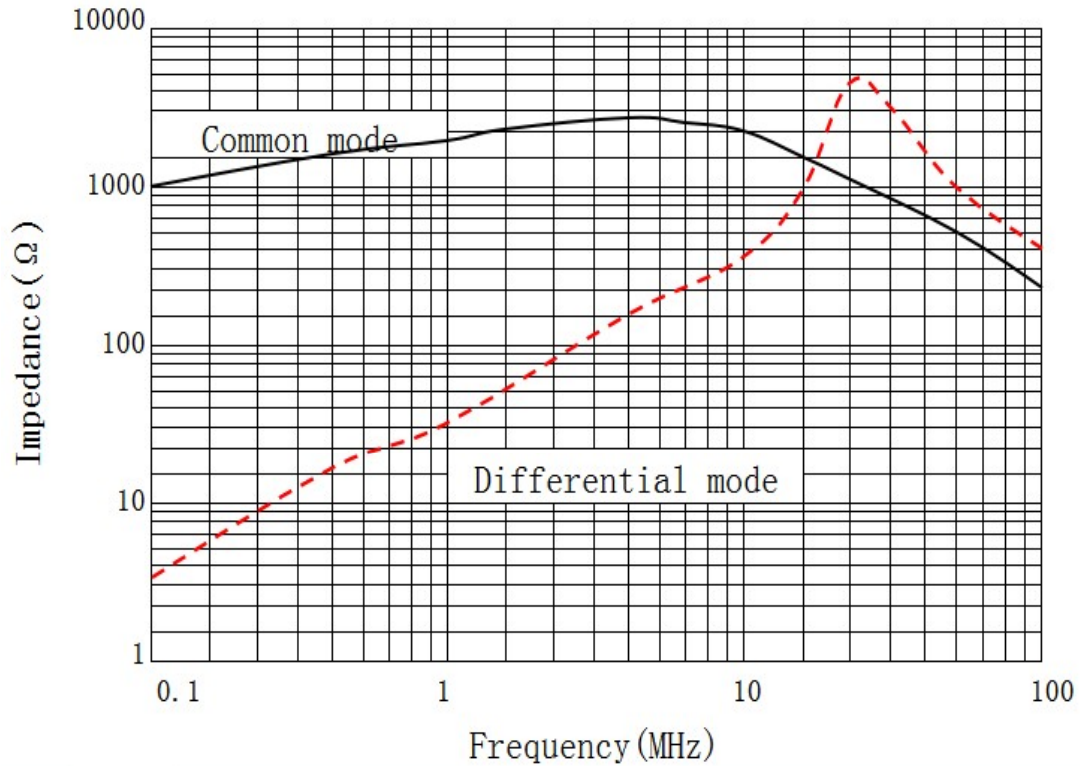

6: 包装 (PACKING)

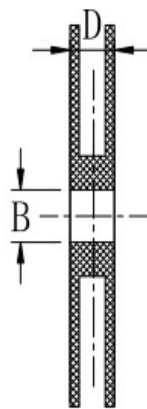
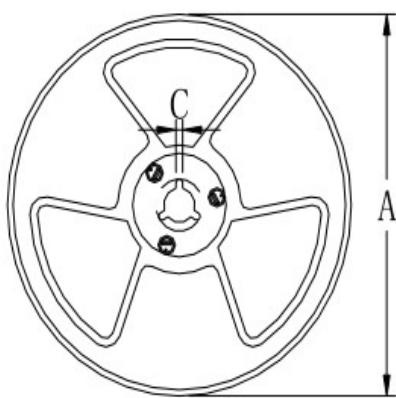

| 规格 尺寸 | 13" | 7" |
|----------|--------------------|--------------------|
| A | $\Phi 330 \pm 2.0$ | $\Phi 178 \pm 2.0$ |
| B | $\Phi 90 \pm 2.0$ | |
| C | 2.3 | |
| D | 30.5 | |

Note:

SPEC. NO. :
Y-21070202